



Undergraduate Student Handbook

2021/2022

FACULTY OF AGRICULTURE

UNIVERSITY OF JAFFNA, SRI LANKA

***** 2023 *****

Copyright: @2023, Faculty of Agriculture, University of Jaffna.

Web : <http://www.agri.jfn.ac.lk/>

Email : aragri@univ.jfn.ac.lk

Telephone: 021 206 0175

Published by: Faculty of Agriculture,
University of Jaffna,
Ariviyal Nagar, Kilinochchi
Sri Lanka

Approved at 237th Meeting of the Faculty Board held on 06.09.2023

*Faculty Sub-Committee compiled and edited the handbook
Mrs. Kasthuri Kajeewan, Miss. Kamshajini Raveendran, Mrs. Thusalini Asharp,
Mr. N. Venugoban and Prof. G. Mikunthan*

Vice Chancellor's Message



I am happy to give this message to the Handbook published by the Faculty of Agriculture which is designed to assist the undergraduates to make their stay in the University a fruitful one. In this respect information and details are provided about offered course units, evaluation procedures, facilities available and especially the awards and scholarships for outstanding performances. Students will get all the necessary academic inputs and on hand experience to make them as readily employable graduates both in state and private sectors as well as globally.

Faculty of Agriculture was started in 1990 and has grown as a full-fledge faculty with all the essential facilities. The students are given adequate exposure on farmers' fields, agro-based industries and research institutions. At the final year they are involved with research projects which are suitable for the regional and national needs.

This guide also directs the students to look on the students' supporting services as well as to adhere to the rules and regulations of the University.

I congratulate the Dean and Staff members of the faculty for updating this student's guide for the effective use of the students.

I wish the freshers to have very productive undergraduate period in University of Jaffna fulfilling the expectation of the community and the nation.

Prof. S. Srisatkunarajah
Vice Chancellor, University of Jaffna

Dean's Message



I am very glad to give this message to the student handbook of the Faculty of Agriculture. The B.Sc. Honours in Agriculture is a unique multidisciplinary degree program offered by the Faculty of Agriculture, University of Jaffna. The faculty was established in 1990 with the mission to produce competent graduates in agricultural technology and agribusiness management through quality education, undertake cutting-edge research, disseminate knowledge and research outputs, and provide extension services to achieve regional, national, and global sustainable agricultural development. The B.Sc. (Agric.) degree program has been designed in compliance with Level 6 of the Sri Lanka Qualification Framework (SLQF).

Agriculture graduates secure rich theoretical knowledge and practical skills with industrial and field exposure, interpersonal skills, teamwork, time management skills, and social and ethical sensitivity. The faculty is also committed to providing excellent student-centered learning facilities and a platform for the students to excel in all extracurricular activities, but in addition, students are required to maintain continual commitment and self-imposed discipline, both of which are fundamental to all life-related matters.

This handbook contains valuable information about the available resources, student responsibilities, basic curricula, examination regulations, and other processes. As an undergraduate, please make use of it, become familiar with your responsibilities, and make the time to take advantage of the many opportunities to get involved. Students will get all the assistance through this handbook, and if students have any clarifications, they can approach student counselors, lecturers, heads of department, and staff from the office of the dean.

As Dean of the faculty, I wish the freshers all the best in their future endeavors.

Prof. S. Vasantharuba
Dean, Faculty of Agriculture

CONTENTS

1. University Education.....	13
1.1. The University of Jaffna.....	13
1.1.1. Brief History.....	13
1.1.2. Crest.....	14
1.1.3. Vision.....	15
1.1.4. Mission.....	15
1.2. Faculty of Agriculture, University of Jaffna.....	15
1.2.1. Brief History.....	15
1.2.2. Vision.....	17
1.2.3. Mission.....	17
1.2.4. Quality Enhancement in University of Jaffna.....	17
2. Administrative Setup of the University - Organogram.....	20
2.1. The Role of the University Grants Commission and the Ministry of Higher Education.....	22
2.2. The Chancellor and Officers of the University.....	22
2.4. Administration of the Faculties.....	23
2.5. The Faculty Board Members.....	24
2.6. The University Senate.....	25
2.7. Other Academic Entities.....	25
2.8. Administrative Branches of the University.....	25
2.8.1. Administration Branch:.....	26
2.8.2. Establishment Branch:.....	26
2.8.3. Examination branch.....	26
2.8.4. Admission and Registration Branch:.....	26

2.8.5. Welfare Services Branch:.....	26
2.8.6. Academic and Publication Branch:.....	27
2.8.7. Finance Branch:.....	27
2.8.8. Engineering Service Division:.....	27
2.8.9. Security Department:.....	27
3. The Structure of the Bachelor Degree Programme	27
3.1. The Objective of the Degree Programme	27
3.2 Graduate Profile	28
3.3. Intended Learning Outcomes of the Degree Programme	28
3.4. Admission Requirements.....	29
3.5 Credit Unit	29
3.6. Types of Course Units and Course Notation.....	30
3.7. The Structure of the Degree Programme	32
3.9. Attendance.....	33
3.10. Specialization and Selection criteria.....	34
3.11. Examination and Evaluation.....	35
3.12. Student Research Project.....	35
3.13. Industrial Training.....	35
3.14. Experiential Learning	36
3.15. Assessment Structure.....	37
3.16. Pass Mark of a Course.....	38
3.17. Repeating Examination	38
3.18. Upgrade a Course Unit	39
3.21. Grade and Grade Point Values	40
3.22. Calculation of Grade Point Average (GPA)	41

3.23. Calculation of the Cumulative Grade Point Average (CGPA)	41
3.24. Criteria for Award of Degree and Eligibility and Cut-off levels of OGPA for Awarding Classes/Pass.....	42
4. Examination Rules and Regulations.....	57
4.1. Examination Arrangements for Students with Special Needs...	57
4.2. Eligibility for Examination without Required Attendance.....	58
4.3. Examination Hall - Attendance	58
4.5. Examination Hall - Seating	58
4.8. Articles Candidates Should Bring	59
4.9. Examination Stationary	59
4.10. Index Number.....	60
4.11. Conduct at Exam Hall	60
4.12. Maintenance of Silence	60
4.13. Copying	60
4.15. Allowing Another Candidate to Appear.....	61
4.16. Unauthorized Items that Candidates Should not Bring	61
4.17. Prohibition of Mobile Phones at Exam Hall (In person exam)	62
4.18. Rough Work to be Cancelled	62
4.19. Unwanted Parts of Answers Should be Crossed Out	62
4.20. Under Supervisors Authority.....	62
4.21. Stopping Work	62
4.22. Handing Over Answer Scripts.....	62
4.23. Leaving the Exam Hall.....	63
4.24. Impersonation.....	63
4.25. Prior Knowledge of Question Paper.....	63

4.26. Dishonesty	63
4.27. Cancellation/Postponement	63
4.28. Making of Statements.....	63
4.29. Whom to Contact for Examination Matters	64
4.30. Withdrawal	64
4.31. Absence from Examination	64
4.32. Submission of a Medical Certificate	64
4.33. Examination Offences and Punishments	65
4.34. Award of Class	67
5. Supportive Facilities for Learning and Extracurricular activities.	67
5.1. The Library.....	67
5.2. The Computer Unit.....	68
5.3. The Physical Education Unit.....	69
5.4 Well-being (We-Be) Centre	70
5.5 Centre for Gender Equity & Equality (CGEE).....	71
5.6 Career Guidance unit (CGU) and Career Guidance Cell (CGC)	72
5.7 University Business Linkage (UBL) Cell.....	72
5.8 Academic Counseling and Mentoring	72
5.9 Response Management System at University of Jaffna	73
5.10. Active Citizenship	75
6. Other Services	76
6.1 Health Center.....	76
6.2 Canteen and Shop.....	76
6.3 Banking Facilities.....	77
6. 3. Financial Aids.....	77

6.3.1. Mahapola Trust Fund	77
6.3.2. Bursary Scheme.....	77
6.3.3 Endowed Scholarships	78
6.3.4 Vice-Chancellor Welfare Fund	78
7. Gold Medals and Prizes.....	78
7.1. Professor Alagaiah Thurairajah Gold Medal - University level	78
7.2 Prof. K. Kunaratnam Gold Medal	78
7.3. Professor Alagaiah Thurairajah Gold Medal - Faculty Level ...	78
7.4. Late Mrs. Puvaneswary Loganathan Memorial Gold Medal....	78
7.5. Late Mrs. Puvaneswary Loganathan Memorial Gold Medal for Agronomy	79
7.6. Late Mr. Senior Nadarajah Gold Medal for Animal Science	79
7.7. Late Dr & Mrs C. Jeyaratnam Memorial Gold Medal for Agricultural Biology	79
7.8. Late Dr & Mrs C. Jeyaratnam Memorial Gold Medal for Agricultural Chemistry.....	79
7.9. Eng. R. Vijayaratnam Memorial Gold Medal for Agricultural Engineering	79
7.10. Prof. Somasundaram Kandiah Endowment Prize.....	80
7.11. Ratnam Reginold Dharmaratnam Memorial Prize	80
7.12. J. M. Rajaratnam Scholarship.....	80
7.13. Thillainayagi Kanagasabapathy Scholarship.....	80
7.14. Sellachi Shanmugam Memorial Scholarship.....	80
7.15. University Prizes (Thambiah Mudaliyar Chatram Trust).....	80
7.16. Canberra Tamil Association (CTA) Scholarship.....	80

7.17. Dean Merit Certificate	80
7.18. Faculty Award	81
7.19. Dean's List	80
8. Awards of Full/ Half Colours	82
9. Students' Union	82
10. Fees.....	84
11. Ethics	85
12. Officials of the University	89
12.1 Principal Officers of the Faculty of Agriculture.....	91
13. Academic Staff of the Faculty of Agriculture	91
14. Telephone Directory.....	95

1. University Education

1.1. The University of Jaffna

1.1.1. Brief History

The great philanthropist Late Sir Pon Ramanathan and Dr Lady Leelavathy Ramanathan were the founding stones of the University of Jaffna. Their assets were used to establish the university with the renowned architectural buildings, facilities and the centenary celebrated Prameshwara temple. The Parameshwara College was established by Sir Pon Ramanathan and then the Parameshwara temple was built by Madam Lady Leelavathy Ramanathan, an Australian born women married to Sir Pon Ramanathan and enshrined the Tamil culture in Sri Lanka. Both Sir Pon Ramanathan and Lady Leelavathy Ramanathan invested all their assets to build up the then Parameshwara College and later was transformed into the Jaffna Campus of the University of Sri Lanka in 1974. This campus was ceremonially inaugurated on 6th October 1974 by the then Prime Minister Her Excellency Srimao Bandaranayake with the late Professor Kailasapathy as its first President. Under the University Act No. 16 of 1978, the Jaffna Campus gained the status of an independent University in January 1979 and became the University of Jaffna. To know more about the history of the University you may visit the following URL: www.jfn.ac.lk/aboutUs.html.

1.1.2. The Crest



The nucleus of the crest of the University of Jaffna figures out an image portrayed the sacred bull [T:நந்தி - *Nanthi*, S:නන්ති] in yellow and white comes from the flag of the Jaffna Kingdom, which was prevailed in the 16th and 17th centuries. The traditional lamp in yellow and white on the left reflects the light of wisdom. The *motto* “மெய்ப்பொருள் காண்பதறிவு” in white encircles the above comes from the famous Tamil literary work, “*Thirukural*” meaning ‘*Wisdom is finding the truth*’. Next in the circle the name of the University in three Languages -Tamil, Sinhala and English in white. The 64 flames in-between two rings in yellow in the outer circle reflect 64 disciplines of learning in Tamil culture. The background of the crest is peacock blue.

“எப்பொருள் எத்தன்மையாயினும் அப்பொருள் மெய்ப்பொருள் காண்பதறிவு” - குறள் 355 : அதிகாரம் - மெய்யுணர்தல்

Means that “*Finding the truth in everything, whatever its nature, is wisdom*”.

“எப்பொருள் யார்யார்வாய்க் கேட்பினும் அப்பொருள் மெய்ப்பொருள் காண்பதறிவு” - குறள் 423 - அதிகாரம் - அறிவுடைமை

Means that “*Finding the truth in everything, whoever said, is wisdom*”.

1.1.3. Vision

“To be a leading centre of excellence in teaching, learning, research and scholarship”.

The University of Jaffna is committed to the search for truth in a diverse field of subjects, as has been emphasized in its *motto* “*Meipporul kanpathu arivu*” (Discernment is Wisdom).

1.1.4. Mission

“To produce intellectual, professionally competent and capable graduates to meet the emerging needs of the national and international community, with a special emphasis on the social, economic and cultural needs of Northern Sri Lanka”.

1.2. Faculty of Agriculture, University of Jaffna

1.2.1. Brief History

The long aspiring thrust of the people of Kilinochchi to establish an agriculture faculty at Kilinochchi was materialized in 1990. The Faculty of Agriculture was established with six departments at Kilinochchi initially at the shared buildings belonged to Regional Agricultural Research Centre [RARC] and In-Service Training Institute [ISTI] of Department of Agriculture on December 3rd, 1990 by the then Vice-Chancellor, Late Prof.A.Thurairajah under the Deanship of late Prof. K. Kandiah. With the limited infrastructure facilities, Late Dr. N.Vivekananthan, the then Deputy Director of Research willingly shared the buildings of the department of Agriculture to commence the study programme. Six batches of students were enrolled until 1996 at the Faculty functioned at Kilinochchi. When the war intensified from Kilinochchi town towards Murugandy, the faculty was compelled to shift it temporarily to Karipaddamurippu for the safety of all however failed to find a

suitable place to settle there and finally the University Council decided to shift the faculty temporarily to Jaffna. The academic programme recommenced in August, 1997 and the Deans office located at the Guest house of Faculty of Medicine, the departments occupied temporarily in rented houses, but was there for more than 13 years. The faculty was functioning in Jaffna with limited facilities in terms of physical resources, especially farms, laboratories and lecture halls.

After the war was ended in 2009, a building complex built at Ariviyal Nagar in Kilinochchi was allocated by the Cabinet to the Faculty of Agriculture. This building complex was renovated with the state fund and Faculty of Agriculture started to function in that place since December 2014. During this year two foreign funded projects from India and Japan were discussed, formulated and submitted for funding aiming to improving the infrastructure facilities at the faculty. The faculty has established crop and livestock farms in Ariviyal Nagar, Kilinochchi to provide a sound practical training in Agriculture to the students. To support the academic programmes as well as the outreach activities, the Faculty has absorbed an Integrated Farm and Training center located at Puliyanakulum. Meantime a skill development center consisting of Conference hall, Computer unit, Library, Canteen and student complex was built with the financial support of the Government of India. These facilities are well utilized by the students as well as the postgraduate students and staff. A full-fledged Research and Training Complex has been established with the support of Japan International Cooperation Agency (JICA) and as a follow up PRECIDA project of Japan is helping the faculty to strengthen the human resources and research and outreach activities. At present, the Faculty of Agriculture is functioning with quite enough facilities for teaching, learning and research.

1.2.2. Vision

“To be a leading center for knowledge and skills of agricultural technology and agribusiness management”

1.2.3. Mission

“To produce competent graduates in agricultural technology and agribusiness management through quality education, undertake cutting edge research, disseminate knowledge and research outputs and provide extension services in order to achieve the regional, national, and global sustainable agricultural development”.

1.2.4. Quality Enhancement in University of Jaffna

Higher education liberates the intellect and opens a world of opportunities for their career, making it possible for each of us to contribute to a progressive and healthy society. The target 4.3 of the Sustainable Development Goal 4: Quality Education of United Nations means by 2030 equal access to all men and women to affordable quality technical, skilled and essential knowledge with practical applications to compete and meet the global demand. It makes more sense on this respect preparing the graduates to be fit into the world of work irrespective of the disciplines and the positions in state or non-state sectors they occupy.

Quality is the ultimate outcome of the higher educational institutions like University of Jaffna and graduates are the real products with necessary qualities empowered with mindset, necessary knowledge, attitudes, with essential skills to excel in their career. The educational system has now focusses on outcome based education (OBE) and student-centered learning (SCL) to develop able graduates to serve to the country.

Quality assurance means that the Universities can guarantee with confidence and certainty that standard of its awards and quality of its education provision and knowledge generation are being maintained. It is the way of auditing the degree of compliance by the University rules, regulations and by-laws developed by the Senate and with standards and guidelines prescribed by the Quality Assurance Council (QAC) codes of practices in line with Sri Lanka Qualifications Framework (SLQF).

University Grants Commission has a system of Quality enhancement channeling through QAC of UGC, Centre for Quality Assurance (CQA) in the Universities and ultimately Faculty Internal Quality Assurance Units (IQAC). The faculty of agriculture has an IQAC to perform all its functions stipulated in the by-laws. The graduates of the University of Jaffna especially those specialize in agriculture are expected to meet the required qualities to be capable to fit into any such engagement.

All the higher educational institutions especially Universities are being assessed by having Institutional Reviews as well as all the degree programs offered by them are also assessed by having Program Reviews to ensure their quality. The desired attributes of quality assessment are objectivity, transparency and comparability. Since all the degree programs are developed based on the SLQF and the Subject Benchmark Statement (SBS) and their delivery is often assessed to improve the quality in a conventional system by setting for Institutional review 10 criteria with 107 standards (Revised in 2023) and for Program review 8 criteria with 156 standards (good practices).

Student engagement is essential in empowering the student's ability and their participation in possible decision-making processes, especially in the faculty board, faculty sub - committees, revision of

curriculum etc. Students' active participation is most expected in different modes of course deliverables especially laboratory and field practical, group discussions, in-plant training, conducting research etc. Students, as well as alumni, are expected to provide feedback, the main instrument used, to assess the quality of the delivery and based on the assessment the possible changes are made.

Gender equality is expected mainly in selecting students in those events and to minimize the sexual and gender based violence by having a good understanding among the university community, provided the policies and bylaws available in the University protect and prevent such incidences.

The stakeholder participation is an essential component to ensure the quality of the programme and such interaction is needed to shape up the degree programme to be fit into the government as well as industrial working environment. Student satisfaction survey, employment survey and graduate's tracer studies are few of the scales used to assess the quality of the graduates produced through this programme.

2. Administrative Setup of the University - Organogram of the University

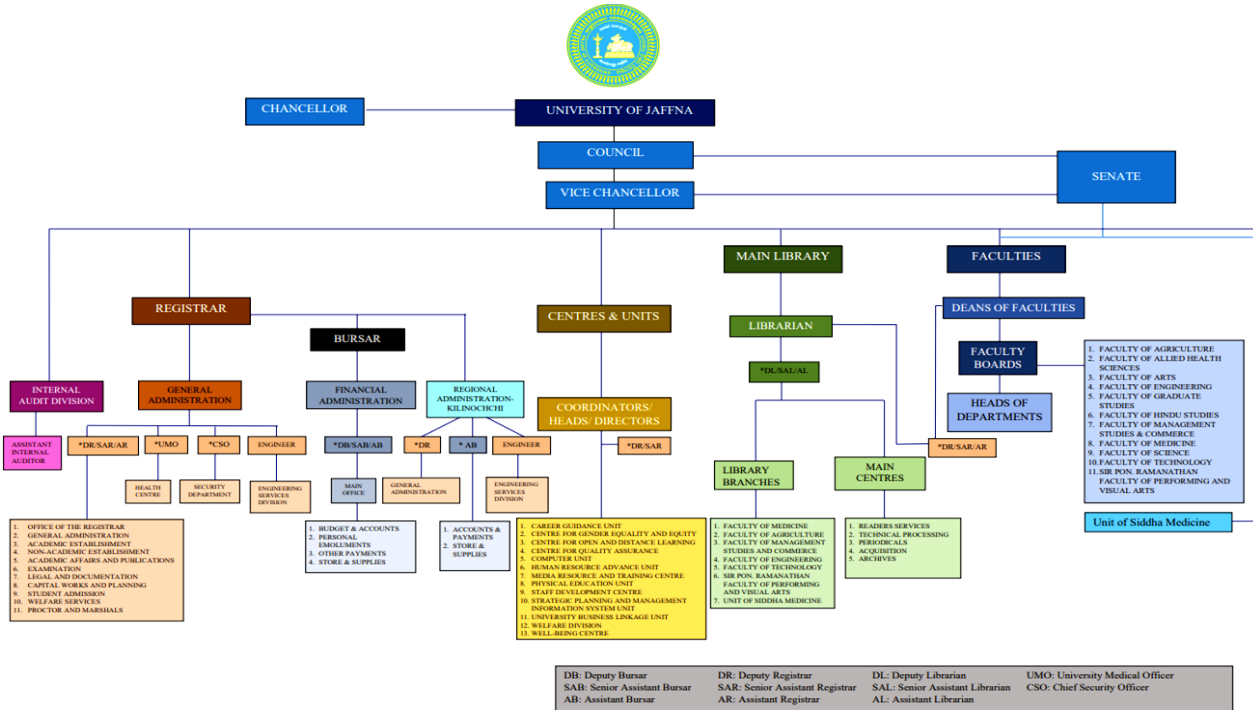

Organogram of the Faculty

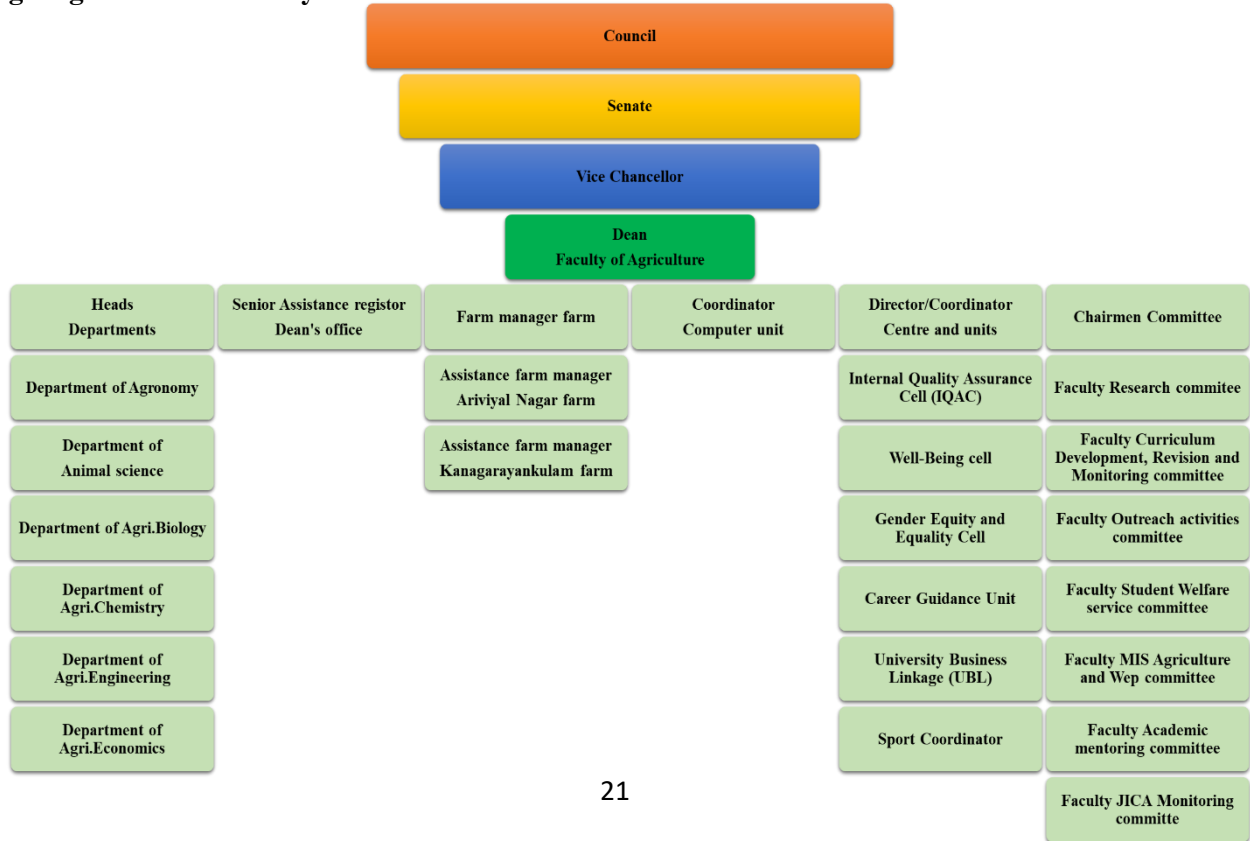

2.1. The role of the University Grants Commission and the Ministry of Education

There are fifteen universities in Sri Lanka and although they are autonomous universities, the financial allocations, for the universities, admission of students, rules and regulations regarding governance and staff recruitments and infrastructure and academic developments of the universities are controlled by the Ministry of Education of the Government through the University Grants Commission (UGC). His Excellency the President of Sri Lanka appoints the Chairman, members of the UGC and the Chancellor of the University.

2.2. The Chancellor and Officers of the University

- Every University has a Chancellor. The Chancellor is the Head of the University and chairs the Annual Convocation of the university. The Principal Executive Officer of a University is its Vice-Chancellor who is also appointed by His Excellency the President.
- The University administration is divided into two sectors: Academic and non-academic.
- Although the Vice-Chancellor is overall in-charge of both academic and non-academic matters, the Registrar is the Principal Executive Officer for all non-academic matters. The officer responsible for the financial sector is the Bursar. There are several Senior Assistants Registrars, Assistant Registrars, Senior Assistant Bursars and Assistant Bursars assisting the Vice-Chancellor/ Registrar/Bursar.

2.3. The Faculties, Units and Academic Departments

There are eleven Faculties in the University of Jaffna located across Northern Province. Eight Faculties are in Jaffna and three in Kilinochchi. In addition, there is BSMS degree awarding Siddha Medicine Unit located in Kaithady, and B.Sc in Sports science awarding Sports Science Unit under the administrative purview of

Faculty of Allied Health Sciences in Jaffna. The faculties and their locations are:

1. Faculty of Agriculture (Ariviyal Nagar, Kilinochchi)
2. Faculty of Allied Health Sciences
3. Faculty of Arts
4. Faculty of Engineering (Ariviyal Nagar, Kilinochchi)
5. Faculty of Graduate Studies
6. Faculty of Hindu Studies
7. Faculty of Management Studies and Commerce
8. Faculty of Medicine
9. Faculty of Science
10. Faculty of Technology (Ariviyal Nagar, Kilinochchi)
11. Sir Ponnambalam Ramanathan Faculty of Performing and Visual Arts

In addition to the above faculties, there are two units which offer degrees. They are;

1. Unit of Siddha Medicine
2. Centre for Open and Distance Learning

Each Faculty has academic Departments of Study. The Faculty of Agriculture, University of Jaffna has the following six academic Departments:

1. Department of Agronomy
2. Department of Animal Science
3. Department of Agricultural Biology
4. Department of Agricultural Chemistry
5. Department of Agricultural Economics
6. Department of Agricultural Engineering

2.4. Administration of the Faculties

Each department is comprised of academic staff (Senior Professors, Professors, Associate Professors, Senior Lecturers, Lecturers and

Probationary Lecturers). Heads of Departments are appointed by the Council of the University from among the senior academic staff.

A Faculty Board, comprising of all the permanent academic staff (confirmed in their posts) of the faculty, two representatives from the probationary lecturers, three members elected from among prominent persons working in disciplines related to the faculty, makes recommendations/decisions regarding academic matters in the Faculty. Two representatives of the students with gender balance are invited to the faculty board meetings as a means of student engagement in quality education.

Each faculty has a Dean, who is the Head of the faculty concerned. The Dean is elected by the Faculty Board from among the Heads of departments. All Faculty Board members excluding the two student representatives are eligible to vote in the election of the Dean. The Dean is the academic and administrative head of the Faculty concerned and the Chairman of the Faculty Board. Each faculty has an Assistant Registrar to assist the Dean with faculty administration.

The Vice-Chancellor, the Deans, the Registrar, the Bursar and the Librarian are the Principal Officers of the University. Students are encouraged to seek assistance from the office of the Dean and the Heads of Departments regarding their study programme and appropriate subject combinations.

2.5. The Faculty Board members

Board Members:

- Dean (Chairperson)
- Heads of all departments
- All permanent and confirmed academic staff
- Two members elected among probationary lecturers
- Three outside members nominated by the faculty board.

Non-Voting Members:

- Two student representatives (Gender balance)

Invited members:

- Farm Manager
- Assistant Librarian
- Other probationary lecturers if needed.
- Senior Assistant Registrar (Secretary)

2.6. The University Senate

The University Senate is the highest academic body of the university. All the Deans, Professors, Heads of Departments and two academics elected from each Faculty are the members of the Senate. The Vice-Chancellor is the Chairman of the Senate and Registrar serve as the Secretary. All recommendations made by the Faculty Board regarding academic matters are referred to the Senate for approval.

2.7. Other Academic Entities

Apart from the Faculties, the university has some academic units. They are:

1. Physical Education Unit
2. Career Guidance Unit
3. Centre for Quality Assurance
4. Strategic Planning & Management and Information System (MIS) Unit
5. Computer Centre
6. Staff Development Centre
7. Gender Equity & Equality Centre
8. University Business Linkage (UBL) Cell
9. Well-Being Centre

2.8. Administrative Branches of the University

A brief account of the work carried by the different administrative sections of the university is given below:

2.8.1. Administration Branch:

Administration branch handles many matters including postal, communication and transport services which are services relevant to the students.

2.8.2. Establishment Branch:

The Establishment branch handles the works relating to university employees for both Academic and Academic supporting (Non-academic) separately.

2.8.3. Examination branch

Examination branch handles the works such as examinations and release of results. It also issues the transcripts and details of examination results at the request of the students.

2.8.4. Admission and Registration Branch:

Admission and Registration branch handles the works such as registration of new entrants selected to the University. In addition, this branch prepares the Degree certificates and maintains the academic records and register of graduates.

2.8.5. Welfare Services Branch:

This branch looks after the welfare of the university students and hence one of the most important administrative organs of the university as far as the students' welfare is concerned. It handles matters such as providing accommodation to students at the university hostels and helping the students to get accommodation outside the university, providing canteen facilities, maintaining social harmony among the students, student counseling, health services and the matters relating to student discipline in the university. It also handles the work relating to the Vice-Chancellor's Fund, the Mahapola and Bursaries etc.

2.8.6. Academic and Publication Branch:

The Academic branch engages itself with the working relating to the Senate meetings, publication of annual reports, books, etc., making arrangements for the convocation and handling the endowments for scholarships, prizes and gold medals.

2.8.7. Finance Branch:

The Finance Branch handles all the financial matters including purchases and supplies, and especially disbursement of the money allocated and payments.

2.8.8. Engineering Service Division:

This branch is responsible for utilities such as water and electricity supply, maintenance of buildings and structures etc.

2.8.9. Security Department:

This Department headed by a Chief Security Officer (CSO), has more than fifty security personnel to protect the properties of the university and give security to the university community.

3. The Structure of the Bachelor Degree Programme in the Faculty of Agriculture, University of Jaffna

3.1. The Objective of the Degree Programme

The objective of the study programme of Agriculture is to produce skilled agricultural graduates embedded with problem solving capacity, ability to work in a team, innovative and creative capacity with entrepreneurial skill in agricultural enterprises leading to sustainable development.

3.2 Graduate Profile

Courses in B.Sc. Hons (Agriculture) degree programme are offered in such a manner to achieve the level 6 in the SLQF and Subject Bench Mark (SBM) enabling graduates to be competent by gaining:

- Sound knowledge in subjects and scientific research methods in Agriculture
- Ability to apply knowledge to solve the problems
- Ability to integrate theory, practical experience and skills gained from different disciplines of Agriculture to face and solve emerging issues in the field
- Social responsibility personally and professionally.
- Numerical and analytical skills to analyze data and information scientifically and draw inferences.
- Innovative and creative skills to solve the problems
- ICT and Communication skills with trilingual proficiency (English, Tamil and Sinhala)
- Interpersonal skills, team work, time management skills, social and ethical sensitivity

3.3. Intended learning Outcomes of the Degree Programme

On completion of the BSc Hons (Agriculture) the graduates should:

- Possess knowledge and management skills to be a professional in agricultural disciplines
- Be acquired analytical and technical skills needed for research and development
- Be able to plan, design, conduct and report experiments
- Have been motivated towards self-learning and team work
- Be able to organize their activities and complete the task on time
- Be acquainted with importance of environmental safety and sustainable farming systems
- Be innovative and apply the concepts in learning and analysis of agricultural systems in a holistic manner
- Have the ethics, professionalism, quantitative, oral and written communication skills to work effectively in agricultural careers

- Be confident towards self-employment
- Be able to work in multi-cultural society
- Be socially responsible and capable of working with farming community

3.4. Admission requirements

Students are admitted to this undergraduate programme by the UGC under Biological Science stream based on z-score obtained in G.C.E (A/L) examination. In addition to this, middle level technical officers with five years of experience from Department of Agriculture who obtained Diploma in Agriculture from any recognized institution and passed the G.C.E (A/L) examination in Biological Science are admitted to this programme based on the performance in the selection exam and interview. However, number of students admitted from Department of Agriculture is limited to maximum of 5% of the total admitted students.

3.5. Credit Units

A credit unit is the numeric value assigned to a course unit, which indicates its relative weight within the degree programme. One credit is considered equivalent to 50 notional learning hours for a taught course, laboratory studies course or field studies. In case of industrial training, experiential learning and social harmony and active citizen, including time allocated for assessments and in case of research, including time allocated for literature survey, one credit is considered equivalent to 100 notional hours. In addition, one credit unit of teacher assisted learning should be either 15 hours of lectures and 35 hours of self-learning (Independent learning) or 30 hours of practical/tutorials/assignments and 20 hours of self-learning (Independent learning).

3.6. Types of Course Units and Course Notation

Types of Course Units

- **Core Course Units:** These course units are designed to equip the students with a comprehensive subject specific knowledge, skills and attitudes on the entire range of fundamental concepts, principles and practices associated with the field of agriculture.
- **Specialization Course Units:** These course units are designed to provide additional knowledge and skills in each specialization field. Specialization courses that are unique to each specialization are compulsory.
- **Complimentary course Units (CC):** These course units are intended to provide the required knowledge skills attitude and mind-set to undertake independent research and to prepare to the working environment.
- **Auxiliary Course Units (AC):** These course units are designed to enhance the generic skills required to supplement the knowledge and skills of students.
- **Elective Course Units:** These course units are designed to provide additional knowledge and skills in each specialization field, which are not compulsory, but a selected number could be chosen by students to follow based on their preference and the advice of the Department of Specialization. Each specialization offers a series of elective courses.

All core course units, complementary and auxiliary course units offered in this degree program are compulsory. Each specialization offers compulsory courses that are unique to each specialization and a series elective courses.

The two alphabets abbreviation of the course code denotes the department / discipline/ auxiliary/ common core courses. Inter-disciplinary course will be jointly denoted by alphabets representing the departments/discipline concerned.

Table 01: Course Letter of the Course units

Course Letter	Department / Discipline / Complementary/Auxiliary courses
AG	Agronomy
AS	Animal Science
AB	Agricultural Biology
SS	Soil Science discipline of Agricultural Chemistry
FS	Food Science discipline of Agricultural Chemistry
AE	Agricultural Engineering
EC	Economics discipline of Department of Agricultural Economics
EX	Extension discipline of Department of Agricultural Economics

The first digit of the five-digit number code denotes the year, second digit denotes the semester, third and fourth digits indicate the subject number and the last digit denotes the credits of the particular subject.

An examples of course notation is given below: AG 11013 Principle of Crop Production denotes

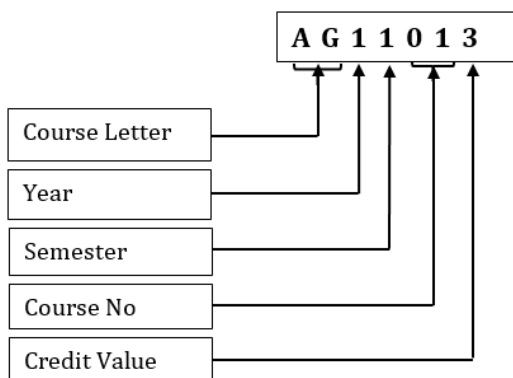

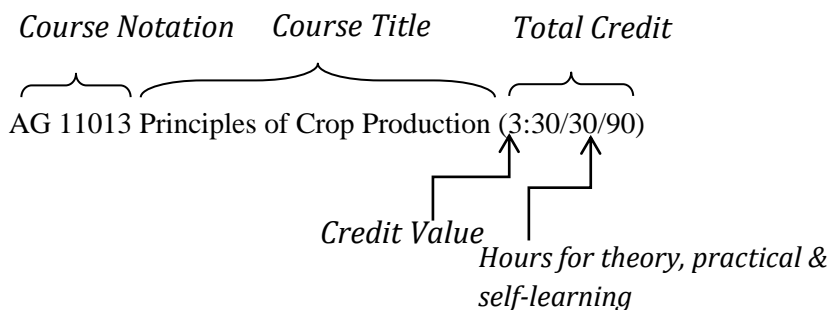

3.7. The Structure of the Degree Programme and Curriculum Layout

BSc Hons (Agriculture) degree is, SLQF Level 6, a four-year programme comprising eight semesters. Each semester has 15 weeks of academic work. Each course is taught and assessed within the particular semester. The programme consists of 127 credit units including 91 core course credit units, 14 complementary course credit units and 22 specialization course credit units. Each specialization module must have a minimum of 14 compulsory credit units that are unique to that specialization and a series of elective courses. Six credit units of research project (CC 42016) is also included in the complementary course credit units. In addition, 16 credit units of auxiliary courses are offered.

Table 02: The Credit distribution of the Degree Programme

Semester	Name of the Semester	Type of Course units	Credits
1	First Year First Semester	Core Courses	14
		Auxiliary courses	07
2	First Year Second Semester	Core Courses	14
		Auxiliary courses	02

3	Second Year First Semester	Core Courses	15
		Auxiliary courses	01
4	Second Year Second Semester	Core Courses	19
		Auxiliary courses	01
5	Third Year First Semester	Core Courses	17
		Complementary Courses	02
		Auxiliary Courses	02
6	Third Year Second Semester	Core Courses	12
		Specialization Courses	04
		Auxiliary Courses	03
7	Fourth Year First Semester	Complementary	06
		Specialization Courses	10
		Elective Courses	08
8	Fourth Year Second Semester	Complementary Course (Research Project)	06
Total credit			127

3.8. Length of the Degree Programme

The degree should be completed within 8 years from the year of registration.

3.9. Attendance

It is mandatory for a student to have 80% attendance in both theory and practical classes for sitting examinations of each course unit. A student who does not satisfy the attendance requirement will be allowed to sit for the examination in the next available attempt as a repeat candidate. Under exceptional circumstances and valid reasons,

with the recommendation of the faculty board and the approval of the senate, a student could be waived off from the attendance requirement.

3.10. Specialization and Selection Criteria

Specialization

The Faculty provides opportunity to pursue eight specializations namely agronomy, animal science, agricultural biology, soil science, food science, agricultural engineering, applied economics and agribusiness management, agricultural extension from third year second semester onwards. Each student must complete a minimum of 22 credits of specialization courses. Each specialization comprises 14 credits of compulsory course units offered by the respective department and a set of elective course units. Elective course units could be chosen by students to follow based on their preference and the advice of the Department of study. Further, a student has the freedom to follow maximum of 6 credit units of specialization courses from other departments over and above the credit requirement of the degree programme from third year second semester onwards. In addition, a student should carry out 6 credit units of research project related to the specialization during the 8th semester.

Selection Criteria for Specialization

Every student will be given an opportunity for specialization. Faculty board of the Faculty of Agriculture decides the minimum and maximum number of students that could be assigned for each specialization based on the number of students and required facilities available in the department/s. Application for specialization will be called in third year first semester. Cumulative Grade Point Average (CGPA) up to 5th semester shall be used as a criterion to assign the students into different specialization areas based on their academic merit.

3.11. Examination and Evaluation

Evaluation system has formative and summative assessments for both theory and practical components. Examinations consist of either theory or practical or combination of both which is based on the course structure. The grade of theory and practical component of a course comprises 30 percent from formative assessment and 70 percent from summative assessment. Marks for the theory and practical components in the final grade of a course will be calculated proportionately to the credit value distributed to the theory and practical components. Final grade of a course that has only theory or practical component comprises 30% from formative assessment and 70% from summative assessment.

3.12. Student Research project

During the second semester of the fourth year, all students will be involved in research project and finally student will submit a dissertation. On completion of the project students shall be requested to present their research project in a seminar session. The dissertation will be evaluated in the following manner.

Presentation	- 30% (Three Member Panel)
Report	- 70% (Three Member Panel)

3.13. Industrial Training

Each student will be assigned to an agro-based industry based on his/her specialization discipline for four weeks during the end semester vacation of third year second semester. On completion of the training the students will share their experience through a presentation and by submitting a report. The presentation and report will be evaluated. This course is evaluated according to the following scheme.

	Criteria	Evaluator	Marks allocated
1	Evaluation by supervisor in the industry/organization	Supervisor from the industry	25%
2	Evaluation of record book	Lecturer in charge of student	15%
3	Report on industrial training	Lecturer in charge of student	20%
4	Presentation on industrial training	Three members nominated by the faculty board	30%
5	Contents uploaded in the e-portfolio/ electronic documentary	Lecturer in-charge of student	10%

3.14. Experiential Learning

During the first semester of the fourth year, all students will be involved in experiential learning. Each student has to work with a host farmer for a semester. During this course of study student assess the available resources, resource allocation, technology adopted, production systems, cost of production and constraints faced by farmers in crops and livestock production. Finally, the student will prepare the report and present it for evaluation. This course will be evaluated in the following manner.

Mid-term Presentation - 15% (Two Member panel appointed by the FB)

Final Presentation - 35% (Three Member panel appointed by FB)

Report and record book - 50%

3.16. Pass Mark of a Course

A student must obtain a minimum of C grade in all courses (compulsory, common core courses and specialization courses) for both practical and theory components separately to qualify for the award of the degree. The auxiliary courses will not carry credit value for the calculation of the Cumulative Grade Point Average (CGPA). But a student must obtain a minimum of C grade in all auxiliary courses for the award of degree.

3.17. Repeating Examination

Formative assessment

If a student is absent for formative assessment due to medical reason or any other valid reasons, he/she has to inform his/her absence to the Head of the Department or course coordinator in writing within three days. The relevant supportive documents such as UMO certified medical certificate or appropriate evidences have to be submitted within a week to Dean/Agriculture.

Summative assessment

If a student is absent for summative assessment due to medical reason, he/ she has to inform his/ her absence to the office of the Dean, Faculty of Agriculture within three days and has to submit UMO certified medical certificate within two weeks. On the request of the student, the next available attempt will be considered as first attempt upon the recommendation of Faculty Board and the approval of the Senate. If a student is absent for summative assessment due to any exceptional reasons, on the request of the student, he/she will be given an opportunity to sit the next available summative assessment as first attempt upon the recommendation of Faculty Board and the approval of the Senate.

A student who obtains a grade C- or below for a course unit may repeat the relevant end of course examination will only be allowed to repeat

a course three times consecutively and the maximum grade for such course unit will be C+. Where relevant, the grade for the repeated course unit will be calculated using the latest end of course examination marks and the in-course assessment marks available.

Mercy Chance to Sit Examinations

If a student fails the course unit at all three repeat attempts, he/she may request for a mercy chance. With the recommendation of faculty board and the approval of the Senate, a mercy chance would be given. For the mercy chance candidates, the marks of summative assessment alone or combination of marks of formative and summative assessment whichever is higher will be taken to compute the final grade.

3.18. Upgrade a Course Unit

A student who obtains a grade C for a course will be allowed to upgrade up to the level of C+ by sitting both or any of the components (practical and theory) of a course only at the next available attempt. If a student obtains a lower grade in the upgrading chance, he/she is entitled to keep the previous grade. Medical certificate will not be accepted if the candidate missed the next available upgrading attempt. Candidate can't upgrade practical and theory in separate attempts.

3.19. Absence for Examinations due to Medical Reasons

If a student is absent for an End-of-Course examination of a particular course unit for reasons acceptable to the Faculty Board and the University Senate, then he/she can sit for that examination in the next available opportunity, and shall retain that attempt. His/her present results will be recorded as Medical Certificate (MC).

3.20. Absence for Examinations due to any Other Reasons

If a student was absent for an End-of-Course examination of a course unit and if the Senate did not accept the reasons submitted by the student or if the student did not give any reasons, his present final

results for that course unit will be recorded as Incomplete (IC). In this case the student may repeat that examinations and the maximum grade obtainable is C+.

3.21. Grade and Grade Point Values

The proposed grades, grade point values and marks are given below

Table 03. Grade, Grade Point Value and Marks

Grade	Grade Point Value (GPV)	Marks
A+	4.00	≥ 85
A	4.00	80 - 84
A-	3.70	75 - 79
B+	3.30	70 - 74
B	3.00	65 - 69
B-	2.70	60 - 64
C+	2.30	55 - 59
C	2.00	50 - 54
C-	1.70	45 - 49
D+	1.30	40 - 44
D	1.00	35 - 39
E	0.00	<35

When a student is absent from or fail any component of the examination, the status of a course unit will be indicated as given in the table below.

Table 04: Description of the status of a course unit

Status of the course unit	Description
<ul style="list-style-type: none"> Ab 	Absent for both Theory and Practical
<ul style="list-style-type: none"> I e.g. I (P) 	Incomplete (Either Theory or Practical component absent) Practical component absent

I (T)	Theory component absent
<ul style="list-style-type: none"> Grade (T) e.g. C⁺ (T) 	Fail (Failed in Theory component)
<ul style="list-style-type: none"> Grade (P) e.g. C⁺ (P) 	Fail (Failed in Practical component)
<ul style="list-style-type: none"> Grade (T, P) e.g. C⁻ (T, P) 	Fail (Failed in both Theory and Practical)

Note: For any other reasons such as “examination offense”, “pending for other actions to complete” for which the results could not be released, the results for that course unit will be recorded either as Exam Offense (EO) or Otherwise (OW).

3.22. Calculation of Grade Point Average (GPA)

An aggregate index will be calculated as a weighted average of the grade and the number of course credit units for each semester. This aggregate index will be referred to as Grade Point Average (GPA) and will be computed using equation 1.

$$GPA = \frac{\sum G_i C_i}{\sum C_i} \dots\dots\dots \text{Equation 1}$$

Where G_i and C_i represent the grade point value and the credit unit of the i^{th} course, respectively.

3.23. Calculation of the Cumulative Grade Point Average (CGPA)

The final GPA obtained by a student on completion of all required courses will be referred to as Cumulative Grade Point Average (CGPA) and will be computed using equation 2. Equal weightage will be given to all semesters for the calculation of the CGPA. The CGPA will be rounded to two digits.

$$CGPA = \frac{\sum_i^8 (GPA_i \times \sum C_i)}{\sum C_i} \dots\dots\dots \text{Equation 2}$$

Where GPA_i represents the Grade Point Average (GPA) of a semester obtained by a student and $\sum C_i$ is the total credit values for the course offered during the respective semester. Auxiliary courses will not carry credit value for the calculation of Cumulative Grade Point Average ($CGPA$).

3.24. Criteria for Award of Degree and Eligibility and Cut-off levels of OGPA for Awarding Classes/Pass

To be eligible for the award of the degree of Bachelor of Science Honours in Agriculture, a student must fulfil the following requirements:

- 1) He/she must complete a minimum of 127 credits comprising 119 compulsory credits that include 91 credits from core course units, 14 credits from complementary course units and 14 credits from compulsory specialization course units and a minimum of 8 credits from elective course units relevant to the specialization.
- 2) He/she must complete 16 credits of auxiliary course units
- 3) He/she must obtain minimum of C grade in all course units contributing to the 127 credits mentioned in 7.1 and all auxiliary course units except AC 32022 English III for which he/she must obtain a minimum of D grade.
- 4) He/she must obtain Overall GPA ($OGPA$) of 2.00 or above

To be eligible for the class, a student must complete the degree within four academic years from the date of commencement of the programme. The cut-off level of Overall Grade Point Average ($OGPA$) values for awarding classes/passes are,

Table 05. Overall Grade Point Average and Class

<i>CGPA</i>	Class/Pass
≥3.70	First Class
3.30 - 3.69	Second Upper
3.00 – 3.29	Second Lower
2.00 – 2.99	Pass

3.24. Details of Course units offered in the Degree Programme

Table 06. Outline of the Credits of the Courses

Semester	Name of the Semester	Series	Courses Offered	
1	First Year	11000	Core Courses	14
2	First Year	12000	Core Courses	14
3	Second Year	21000	Core Courses	15
4	Second Year	22000	Core Courses	19
5	Third Year First Semester	31000	Core Courses	17
			Complementary	02
6	Third Year Second Semester	32000	Core Courses	12
			Specialization Courses	04
7	Fourth Year First Semester	41000	Complementary	06
			Specialization (Compulsory Elective)	18 (10+8)
8	Fourth Year Second	42000	Complementary (Research))Project	06
Total				127

Note: T- Theory, P- Practical and IL - Independent learning

Table 07. Pre-Semester Course units

No.	Code	Title	Credits (T/P/IL)
1	AC 11012	Computer Literacy and Basic Application	2:15/30/55
2	AC 11022 (AE / EC)	Basic Mathematics	2:30/00/70
3	AC 11032	English I	2:30/00/70
4	AC 11041 (FS / AB)	Laboratory Techniques	1:00/30/20

Table 08. First Year Second Semester - Core Courses (11000)

No.	Code	Title	Credits (T/P/IL)
1.	AG 11013	Principles of Crop Production	3:30/30/90
2.	AS 11012	Principles of Animal Production	2:23/15/62
3.	AB 11012	Cell Biology and Crop Botany	2:15/30/55
4.	SS 11012	Nature of Soils	2:15/30/55
5.	AE 11012	Applied Hydrology and Engineering Drawing	2:15/30/55
6.	EC 11013	Principles of Micro and Macroeconomics	3:45/00/105
	Total		14

Table 09. First Year Second Semester - Core Courses (12000)

No.	Code	Title	Credits (T/P/IL)
1.	AG 12012	Cereal Crops Production	2:20/20/60
2.	AS 12012	Anatomy and Physiology of Farm Animals	2:23/15/62
3.	AB 12012	Plant Physiology and Environmental Biology	2:23/15/62
4.	SS 12013	Soil Properties and Processes	3:30/30/90
5.	AE 12013	Principles of Farm Machinery	3:30/30/90
6.	EX 12012	Agricultural Extension and Communication	2:15/30/55
7.	AC 12012	English II	2:30/00/70
	Total		14

Table 10. Second Year First Semester - Core Courses (21000)

No.	Code	Title	Credits (T/P/IL)
1.	AG 21012	Field Crops Production	2:15/30/55
2.	AG 21022	Plant Propagation and Nursery Management Techniques	2:20/20/60
3.	AS 21012	Applied Animal Nutrition and Forage Production and conservation	2:23/15/62
4.	AB 21012	Economic Entomology	2:15/30/55
5.	FS 21012	Biochemistry	2:20/20/60
6.	AE 21013	Water Resource Engineering	3:30/30/90
7.	EC 21012	Intermediate Microeconomics	2:30/00/70
8.	AC 21011	Social Harmony and Active citizen	1:00/30/70

	Total	15
--	--------------	-----------

Table 11. Second Year Second Semester - Core Courses (22000)

No.	Code	Title	Credits (T/P/IL)
1.	AG 22012	Horticulture I	2:20/20/60
2.	AG 22022	Principles of Forestry	2:23/15/62
3.	AS 22012	Livestock Breeding and Health Management of Farm Animals	2:15/30/55
4.	AS 22023	Ruminant Management	3:23/45/82
5.	AB 22012	Basic Microbiology and Phytopathology	2:15/30/55
6.	FS 22013	Principles of Food science and Nutrition	3:30/30/90
7.	AE 22012	Land Surveying and Irrigation	2:23/15/62
8.	EC 22013	Agribusiness Management and Business Accounting	3:30/30/90
9.	AC 22011	Career Guidance and Skill Development	1:00/30/20
	Total		19

Table 12. Third Year First Semester - Core Courses (31000)

No.	Code	Title	Credits (T/P/IL)
1.	AG 31012	Horticulture II	2:15/30/55
2.	AS 31013	Management of Non Ruminants and Aquaculture Technology	3:30/30/90
3.	AB 31013	Plant Protection	3:30/30/90

4.	AB 31022	Agricultural Biotechnology	2:23/15/62
5.	SS 31013	Soil Classification, Soil Fertility and Plant Nutrition	3:30/30/90
6.	AE 31012	Postharvest Engineering	2:23/15/62
7.	EC 31012	Agriculture and Food Marketing	2:15/30/55
8.	CC 31012	Statistical Methods	2:23/15/62
9.	AC 31012	Principles of Management	2:30/00/70
	Total		19

Table 13. Third Year Second Semester - Core Courses (32000)

No.	Code	Title	Credits (T/P/IL)
1.	AG 32012	Plantation and Export Crops Production	2:23/15/62
2.	AS 32012	Animal Product Processing Technology	2:15/30/55
3.	AB 32012	Genetics and Plant Breeding	2:23/15/62
4.	FS 32012	Food Technology	2:20/20/60
5.	AE 32012	Environmental Engineering	2:23/15/62
6.	EC 32012	Introduction to Econometrics	2:23/15/62
7.	AC 32011	Scientific Writing	1: 00/30/20
8.	AC 32022	English III	2: 30/00/70
	Total		12

Table 14. Third Year Second Semester - Specialization Courses

No.	Code	Title	Credits (T/P/IL)
Department of Agronomy			
9	AG 32022	Resilient and Sustainable Cropping System	2:23/15/62
10.	AG 32032	Commercial Floriculture	2:23/15/62
Department of Animal Science			
9	AS 32022	Sustainable Animal Breeding	2: 23/15/62
10.	AS 32032	Marine and Inland Fish Production	2: 23/15/62
Department of Agricultural Biology			
9	AB 32022	Agricultural Acarology	2: 23/15/62
10.	AB 32032	Nematology	2:23/15/62
Department of Agricultural Chemistry			
<i>Soil Science</i>			
9	SS 32022	Soil Physics for Sustainable Agriculture	2: 20/20/60
10.	SS 32032	Soil Chemistry	2: 23/15/62
<i>Food Science</i>			
9	FS 32022	Food Chemistry	2:23/15/62
10.	FS 32032	Food Microbiology	2:23/15/62
Department of Agricultural Engineering			
9	AE 32022	Irrigation and Water Management	2:23/15/62
10.	AE 32032	Farm Machinery Testing and Evaluation	2:23/15/62

Department of Agricultural Economics			
<i>Applied Economics and Agribusiness Management</i>			
9	EC 32022	Agricultural Development and Policy Analysis	2:30/00/70
10.	EC 32032	Natural Resource and Environmental Economics	2:23/15/62
<i>Agricultural Extension</i>			
9.	EX 32022	Extension Education	2:15/30/55
10.	EX 32032	Development Communication	2:23/15/55

Table 15. Fourth Year First Semester - Core Courses

	Code	Title	Credits (T/P/IL)
1.	CC 41012	Experimental Design	2:30/00/70
2.	CC 41022	Computer Application in Biostatistics	2:00/60/40
3.	CC 41031	Experiential Learning	1:00/00/100
4.	CC 41041	Industrial Training	1:00/00/100
	Total		6

Table 16. Fourth Year First Semester - Specialization Courses

Specialization Courses offered by Department of Agronomy

Compulsory Courses		Elective Courses	
Code	Course Title, Credits (T/P/IL)	Code	Course Title, Credits (T/P/IL)

AG 41012	Advance Crop Physiology (2:23/15/62)	AG 41062	Commercial Orchard Crop Production (2:23/15/62)
AG 41022	Sustainable Weed Management (2:23/15/62)	AG 41072	Protected Agriculture Techniques (2:23/15/62)
AG 41032	Landscape Architecture (2:23/15/62)	AG 41082	In vitro Propagation Techniques (2:23/15/62)
AG 41042	Sustainable Forest Management (2:23/15/62)	AG 41092	Crop Simulation Modelling (2:23/15/62)
AG 41052	Climate Change Mitigation and Adaptation in Agriculture (2:23/15/62)	AG 41102	Organic Crop Production Systems (2:23/15/62)

Specialization Courses offered by Department of Animal Science

Compulsory Courses		Elective Courses	
Code	Course Title, Credits (T/P/IL)	Code	Course Title, Credits (T/P/IL)
AS 41012	Dairy Technology and Lactation physiology (2: 23/15/62)	AS 41062	Seafood processing and Post-harvest Technology (2: 23/15/62)
AS 41022	Meat Production and Technology (2:23/15/62)	AS 41072	Animal By-product Technology (2: 30/00/70)

AS 41032	Reproductive Physiology (2: 23/15/62)	AS 41082	Wild life of Economic Importance (2: 23/15/62)
AS 41042	Advanced Animal Nutrition (2: 23/15/62)	AS 41092	Ornamental Fisheries (2: 23/15/62)
AS 41052	Animal Biotechnology (2: 23/15/62)	AS 41102	Integrated Animal Production Systems (2: 23/15/62)
		AS 41112	Micro livestock Production (2: 23/15/62)
		AS 41122	Inland and Marine Fisheries Management (2: 23/15/62)
		AS 41132	Avian Health and Hygiene (2: 23/15/62)

Specialization Courses offered by Department of Agricultural Biology

Compulsory Courses		Elective Courses	
Code	Course Title, Credits (T/P/IL)	Code	Course Title, Credits (T/P/IL)
AB 41012	Integrated Pest Management (2:23/15/62)	AB 41062	Soil Borne Pathogens (2:23/15/62)
AB 41022	Invertebrate Pathology (2:23/15/62)	AB 41072	Biological Control of Pests (2:23/15/62)
AB 41032	Genetic Engineering (2:23/15/62)	AB 41082	Vermitechnology and Biowaste Management

			(2:23/15/62)
AB 41042	Plant Biotechnology (2:23/15/62)	AB 41092	Microbial Inoculants in Agriculture (2:23/15/62)
AB 41052	Clinical plant Pathology (2:23/15/62)	AB 41102	Plant Tissue Culture (2:23/15/62)
		AB 41112	Vertebrate Pest Management (2:23/15/62)
		AB 41122	Apiculture (2:23/15/62)
		AB 41132	Mushroom Cultivation (2:23/15/62)
		AB 41142	Transgenics in Crop Improvement (2:30/00/70)
		AB 41152	Molecular Plant Pathology (2:23/15/62)

Specialization Courses offered by Department of Agricultural Chemistry

Food Science Specialization

Compulsory Courses		Elective Courses	
Code	Course Title, Credits (T/P/IL)	Code	Course Title, Credits (T/P/IL)
FS 41013	Food preservation Technology (3:30/30/90)	FS 41052	Food product Development (2:15/30/55)

FS 41023	Food Analysis (3:30/30/90)	FS 41062	Processing of foods of plant origin (2:23/15/62)
FS 41032	Food and Nutrition (2:23/15/62)	FS 41072	Sensory evaluation of Foods (2:23/15/62)
FS 41042	Food Safety and sanitation (2:23/15/62)	FS 41082	Food packaging (2:23/15/62)
		FS 41092	Fermentation Technology (2:23/15/62)
		FS 41102	Food Lipids (2:23/15/62)
		FS 41112	Functional Foods and Nutraceuticals (2:23/15/62)

Soil Science Specialization

Compulsory Courses		Elective Courses	
Code	Course Title, Credits (T/P/IL)	Code	Course Title, Credits (T/P/IL)
SS 41013	Land resource management and GIS applications (3: 30/30/90)	SS 41062	Soil and Environmental Management (2:15/30/55)
SS 41022	Soil and Plant Analytical Techniques (2: 23/15/62)	SS 41072	Soil management based community project (2: 15/30/55)
SS 41033	Sustainable plant Nutrition (3:30/30/90)	SS 41082	Soil taxonomy and soils of Sri Lanka (2:23/15/62)

SS 41042	Soil Biology and fertility (2:15/30/55)		
SS 41052	Soil organic matter and biodiversity (2: 15/30/55)		

Specialization Courses offered by Department of Agricultural Engineering

Compulsory Courses		Elective Courses	
Code	Course Title, Credits (T/P/IL)	Code	Course Title, Credits (T/P/IL)
AE 41012	Renewable energy and sustainable development (2:23/15/62)	AE 41072	Machinery and structural design (2:15/30/55)
AE 41022	Food processing engineering (2:23/15/62)	AE 41082	Engineering mechanics (2:23/15/62)
AE 41032	Hydrological modelling of rainfall and runoff (2:30/00/70)	AE 41092	Electrical power & machines (2:23/15/62)
AE 41042	Post-harvest technology and machinery management (2:23/15/62)	AE 41102	Cleaner production technology (2:23/15/62)
AE 41052	Industrial bio-process technology (2:23/15/62)	AE 41112	Thermal technologies for biomass processing (2:23/15/62)

AE 41062	Tillage and soil dynamics (2:23/15/62)	AE 41122	Application of chemo metrics in environmental engineering (2:23/15/62)
----------	---	----------	---

Specialization Courses offered by Department of Agricultural Economics

Applied Economics and Agribusiness Management Specialization

Compulsory Courses		Elective Courses	
Code	Course Title, Credits (T/P/IL)	Code	Course Title, Credits (T/P/IL)
EC 41012	International Trade and Monetary Economics (2:30/00/70)	EC 41062	Introduction to Management Science and Linear Programming (2:15/30/55)
EC 41022	Rural Economics and Agricultural Household Models (2:15/30/55)	EC 41072	Marine Resource Economics and Bio Economic Modelling (2:15/30/55)
EC 41032	Econometrics (2:23/15/62)	EC 41082	Industrial Organization (2:30/00/70)
EC 41042	Project Analysis (2:30/00/70)	EC 41092	Introduction to Game Theory (2:30/00/70)
EC 41052	Entrepreneurship Development in Agriculture (2:15/30/55)	EC 41102	Marketing Management (2:30/00/70)

		EX 41052	Human Resource Management (2:30/00/70)
		EC 41112	Food Supply Chain Management (2:30/00/70)
		EC 41122	Planning and Promotion of Agro-Enterprises (2:15/30/55)
		EC 41132	Financial Management (2:30/00/70)
		EC 41142	Intermediate Macroeconomics (2:30/00/70)

Agricultural Extension Specialization

Compulsory Courses		Elective Courses	
Code	Course Title, Credits (T/P/IL)	Code	Course Title, Credits (T/P/IL)
EX 41012	Community Development Approaches (2:23/15/62)	EC 41032	Econometrics (2:23/15/62)
EX 41022	Rural Sociology (2:23/15/62)	EC 41052	Entrepreneurship Development in Agriculture (2:15/30/55)
EX 41032	Project Development and Management (2:23/15/62)	EC 41092	Introduction to Game Theory (2:30/00/70)

EX 41042	Social Research Methods (2:23/15/62)	EC 41102	Marketing Management (2:30/00/70)
EX 41052	Human Resource Management (2:30/00/70)	EC 41112	Food Supply Chain Management (2: 30/00/70)
		EC 41122	Planning and Promotion of Agro-Enterprises (2:15/30/55)
		EC 41132	Financial Management (2:30/00/70)

Table 18. Fourth Year Second Semester Course (42000)

	Code	Title	Credits (T/P/IL)
1.	CC 42016	Research Project	6:00/00/600

4. Examination Rules and Regulations

4.1. Examination Arrangements for Students with Special Needs

Any student who requires special facilities to be arranged for or additional time to complete an In-course / End semester exam may request the Dean in writing for the provision of such before one month of such examination. The Faculty Board shall decide to recommend an additional time of 10 minutes per hour of the examination to a maximum of 30 minutes for a written examination of three or more hours' duration. In case of practical examination, additional time would be decided based on the recommendation of the respective department

4.2. Eligibility for Examination without Required Attendance

A candidate who lacks the required minimum attendance of 80% in any Course Unit under exceptional circumstances but has attended sufficient classes may be allowed to sit the examination with the approval of the Faculty Board and the Senate. Allowing a candidate who lacks the required minimum attendance to sit the repeat examination shall be subject to approval by Faculty Board and Senate. Approval by Faculty Board and the Senate is also necessary to allow a candidate to sit an examination after eligible number of attempts of an examination is exhausted.

4.3. Examination Hall - Attendance

Candidates shall be in attendance outside the examination hall at least 15 minutes before the commencement of each paper, but shall not enter the hall until they are requested to do so by the Supervisor.

4.4. Admission to Examination Hall

A candidate shall not be allowed to enter the examination hall for any reason after the expiry of 30 minutes from the commencement of the examination and shall not be allowed to leave the hall until 30 minutes before the closure of the examination. However, under exceptional circumstances or in cases where the duration of the examination is less than one hour, candidates, shall be allowed to leave the examination hall 15 minutes prior to the closure of the examination.

4.5. Examination Hall - Seating

On admission to the hall a candidate shall occupy the seat allowed to him/her and shall not change it except on the specific instruction of the Supervisor.

4.6. Documents for Identity

A candidate shall have his/her student identity card/record book/admission card with him/her in the examination hall on every occasion he/she presents himself/herself for an examination paper. His/her candidature is liable to cancelled if he/she fails to produce the student record book/student identity card/student admission card when

requested to do so. The student identity card should be clearly visible during the time of examination.

4.7. Declaration

If the candidate fails to bring the required item(s) on any occasion, he/she shall sign a declaration in respect of the paper for which he/she had not produced the item(s), in the form provided for it and produce the item(s) on the next occasion when he appears for the examination. If failure occurs for the last paper of the examination or the only paper he/she is sitting, he/she shall produce the item(s) to the Examination Registrar on the following day. If a candidate has lost his/her documents during the course of examination, he/she shall obtain duplicate(s) from the Examination Registrar for purpose of production at the examination hall.

4.8. Articles Candidates Should Bring

Candidates shall bring to the examination hall only the permitted stationery such as pens, ink, mathematical instruments, erasers, pencils, rulers or any other equipment or stationary which the candidates have been instructed to bring.

4.9. Examination Stationary

Examination stationary (i.e. writing paper, graph paper, drawing paper, ledger paper, precise paper etc.) will be supplied as and when necessary. No sheet of paper or answer book supplied to candidate may be torn, crumpled, folded or otherwise mutilated. No other papers shall be used by candidates. Log tables or any other materials provided by the University shall be used with care and left behind on the desk. Such material supplied whether used or unused, shall be left behind on the desk and not removed from the examination halls.

4.10. Index Number

Before commencement of answering, candidates should write their Index Number with the code and the name of the examination in the allotted spaces. All papers used should carry the Index Number of the candidate. A candidate who inserts on his/her answer script an index number other than his/her own is liable to be considered as having attempted to cheat. The Supervisor/Invigilator has the authority to check the answer script of the candidate. A script that bears no index number or an index number that cannot be identified is liable to be rejected. A candidate shall not write his/her name or any other identifying mark on the answer script.

4.11. Conduct at Exam Hall

Every candidate shall conduct himself/herself in the examination hall and its precincts so as not to cause disturbance or inconvenience to the Supervisor or his/her staff or to other candidates. When entering and leaving the hall, the candidate shall conduct himself/herself as quietly as possible. A candidate is liable to be excluded from the examination hall for disorderly conduct.

4.12. Maintenance of Silence

Absolute silence shall be maintained in the examination hall and its precincts. A candidate is not permitted for any reason whatsoever to communicate or have any dealings with any person other than the Supervisor/Invigilator. In case of urgent necessity, the candidate may communicate with the Supervisor/Invigilator. The attention of the Supervisor/Invigilator shall be drawn by raising his hand from where he is seated.

4.13. Copying

No candidate shall copy or attempt to copy from any book or paper or notes or similar material or from the answer scripts of another candidate. A candidate shall neither help another candidate nor obtain help from another candidate or person. A candidate shall not conduct himself/herself negligently in any way that gives opportunity for another candidate to read anything written by him/her or to watch any practical work conducted by him/her. A candidate shall not use any

other unfair means to obtain or render improper assistance at the examination. Need for assistance for genuine purposes should be indicated to the Supervisor/Invigilator by raising the hand. Any candidate who has been found to have copied from another candidate by an examiner at the time of marking shall be treated as having committed a punishable offence.

4.14. Cheating

A candidate shall not produce in full or an extract of any work other than his/her, without stating so, in a session paper, assignment, reference, research paper, practical or field book or thesis as it amounts to theft of intellectual property. A candidate shall not submit a practical record book or field book or dissertation or project study report or answer script which has been done wholly or partly by anyone other than the candidate, exception being group projects of students.

4.15. Allowing Another Candidate to Appear

A candidate shall not allow another person to appear on his/her behalf for an examination and shall not appear on behalf of another. Supervisors and Invigilators are authorized to obtain declarations from examination candidates regarding any such event occurring within the examination hall.

4.16. Unauthorized Items that Candidates Should not Bring

A candidate shall not have on his/her person or on his/her clothes, or on the admission card, timetable/student record book/student identity card any notes, signs or formulae etc. except those items that are permitted. All unauthorized items a candidate has brought with him/her shall be kept at a place indicated by the Supervisor/Invigilator. A candidate may be requested by the Supervisor to declare any item in his/her possession.

4.17. Prohibition of Mobile Phones at Exam Hall (In Person Exam)

Being in possession of and using mobile telephones or devices capable of storing data are strictly prohibited in the examination hall.

4.18. Rough Work to be Cancelled

All calculations and rough work shall be done only on paper supplied for the examination, and shall be cancelled and attached to the answer script. Such work should not be done on admission cards, time tables, question papers, record books or on any other paper. Any candidate who disregards these instructions will be considered as having written notes or outline of answers with the intension of copying.

4.19. Unwanted Parts of Answers Should be Crossed Out

Any answer or part thereof which is not intended to be considered for the purpose of assessment shall be neatly crossed out. If the same question has been attempted in more than one place parts that are not to be counted shall be neatly crossed out.

4.20. Under Supervisors Authority

Candidates are under the authority of the Supervisor and shall assist him/her by carrying out his/her instructions and those of the Invigilators, during and immediately before and after the examination.

4.21. Stopping Work

Candidates shall stop work promptly when ordered by the Supervisor/Invigilator to do so. If the instruction is not strictly followed, the Supervisor/Invigilator has the authority to make an endorsement to that effect on the answer script.

4.22. Handing over Answer Scripts

Every candidate should personally hand over his/her answer script to the Supervisor/Invigilator. Candidates shall remain seated until all the answer sheets are collected and an announcement is made by the Supervisor that they may leave. Answer scripts shall not be handed to Hall Attendants or any other person under any circumstance. Answer

scripts, once handed over to the Supervisor/Invigilator, shall not be returned to the candidate, and candidates should refrain from such request. No candidate shall remove his/her or any other candidate's answer script from the examination hall.

4.23. Leaving the Exam Hall

Every candidate should personally hand over his/her answer script to the Supervisor/Invigilator. Candidates shall remain seated until all the answer sheets are collected and an announcement is made by the Supervisor that they may leave. Answer scripts shall not be handed to Hall Attendants or any other person under any circumstance. Answer scripts, once handed over to the Supervisor/Invigilator, shall not be returned to the candidate, and candidates should refrain from such request.

4.24. Impersonation

No person shall impersonate a candidate at the examination and a candidate shall not allow another person to impersonate him/her.

4.25. Prior Knowledge of Question Paper

No candidate shall obtain or seek to obtain prior knowledge of questions of an examination paper

4.26. Dishonesty

Serious notice will be taken of any dishonest assistance given to a candidate, by any person.

4.27. Cancellation/Postponement

If circumstance arises which in the opinion of the Supervisor render the cancellation or postponement of the examination necessary, the Supervisor shall stop the examination, collect the answer scripts already written and the report the matter as soon as possible to the Dean of the relevant Faculty.

4.28. Making of statements

The Supervisor/Invigilator is empowered to request any candidate to make a statement in writing on any matter which may have arisen during the course of the examination and such statement shall be

signed by the candidate. Candidate shall not refuse to make such statement or to sign it. In the event of refusal, the Supervisor/Invigilator shall record his/her own observations and report the matter to the Dean of the relevant Faculty.

4.29. Whom to Contact for Examination Matters

A candidate shall not get in touch with anyone other than the Vice-Chancellor, Dean, Head of Department or Examination Registrar regarding any matter concerning the examination.

4.30. Withdrawal

Every candidate who registered for a course/course unit shall be deemed to have sat the examination of the course/course unit unless he/she withdraws from the examination within the specified period for dropping the course/course unit.

4.31. Absence from Examination

When a candidate is unable to present himself/ herself for any part or section of an examination, he/she shall notify or cause to be notified this fact to the Deputy Registrar (Examinations) immediately. This should be confirmed in writing with supporting documents within 48 hours by Registered post.

4.32. Submission of a Medical Certificate for the Inability to Sit Examinations

1. **Informing inability to appear exam:** A candidate who is unable to appear for examinations on medical grounds shall inform of his/her inability to attend the examination to the Dean of the Faculty within a week after the commencement of the examination.
2. **Valid medical certificate:** Those who were unable to appear for examinations on medical grounds should obtain a valid medical certificate from a government hospital in his/her residential area and submit it to the University Medical Officer at the earliest possible. Those receiving treatment from private practitioners of Western, Ayurvedic or Homeopathic medicine should submit the medical certificate during the period of illness to the University

Medical Officer for approval. All medical certificates shall conform to Senate Regulations.

3. **Submission of Medical certificate:** Medical certificate recommended by the university medical officer should be submitted by the candidate to the Dean of relevant Faculty within 14 days of the conclusion of the examination.
4. **Absence from examination:** When a candidate is unable to present himself for any part/section of an examination, he/she shall notify or cause to be notified this fact to the Dean of the Faculty immediately. This should be confirmed in writing with supporting documents within two weeks by registered post.

4.33. Examination Offences and Punishments

Any candidate who violates the rules of examination shall be deemed guilty of examination offences.

Examination offences comprise the following:

- Being in possession of unauthorized documents in the examination hall.
- Being in possession of mobile telephones or devices capable of storing data in the examination hall, without prior permission.
- Removing examination stationery out of the examination hall.
- Copying or attempting in any manner to copy.
- Being in possession of or attempting to use examination stationery that has not been distributed in the examination hall on the day itself.
- Keeping notes on body or on clothes.
- Theft of intellectual property including reproduction of work by others or using information obtained from the Internet without acknowledgment.
- Having or attempting to have unlawfully prior knowledge of all or part of the contents of a question paper or marking scheme of an examiner.
- Entering the examination hall without permission of Supervisor/Invigilator.

- Leaving the examination hall without permission of Supervisor/Invigilator or attempting to do so or assisting others in such acts.
- Destroying, or attempting or assisting to destroy any paper/answer book.
- Disturbing the smooth functioning and peaceful atmosphere of the examination hall.
- Behaving in a manner that is injurious to the self-respect of and/or causes mental stress to a Supervisor/Invigilator/Hall Attendant.
- Planning or attempting to harm mentally or physically a Supervisor/Invigilator/Hall Attendant.
- Impersonation or attempted impersonation including allowing another person to appear at the examination in place of the candidate and using the index number of another candidate.
- Any other examination offence as determined by the Senate.
- Offences identified by the marking examiner.
- Aiding and abetting in examination offences.

The punishment for examination offences could be any one or more of the following depending on the type and seriousness of the offense:

- Cancellation of candidature in the examination in which the offence was committed.
- Cancellation of the candidature from all the examinations of all the course units pertaining to the particular Semester in which the offence was committed.
- Cancellation of candidature in all examinations of the University for three years including the examination in which the offence was committed.
- Cancellation of candidature from the particular module comprising the dissertation, and suspension from the University for two additional semesters.
- Refrain from the eligibility for a class or for an admission to a Honours degree.

- Cancellation of the candidature from the degree and denial of eligibility to register for any degree of the University for one year.
- Expulsion as a Candidate of the University and/or appropriate legal action and/or withdrawal of the Degree / Awards

The minimum punishments for the examination offences shall be as follows:

- Possession of unauthorized documents or removal of examination stationary- cancellation of candidate from the examination in which the offence was committed.
- Disorderly conduct of a grave nature, copying, cheating, attempting to obtain or obtaining improper assistance - cancellation of candidature for three years including the one in which the offence was committed.
- Impersonation - cancellation of candidature for five years including the one in which the offence was committed.

Punishments shall be enhanced depending on the gravity of each case.

4.34. Award of Class

A student will be eligible for award of class if all requirements for the award of class are met within the prescribed period for the degree. However, candidate found guilty of an examination offence shall not be eligible for award of class.

5. Supportive Facilities for Learning and Extracurricular activities

5.1. The Library

The main Library of the University of Jaffna is situated in front of the Students Centre. It is named late Prof. S.Vithiananthan, the first Vice-Chancellor of the Jaffna University, as “Vithiananthan Library”. Access to this building is from the Western side of the building facing the Science Faculty.

Opening hours:

- Weekdays - 8.30 am to 4.30 pm

- Saturday, Sunday and Public Holidays - Closed

There are branch libraries located in the respective faculties such as Faculty of Agriculture, Faculty of Engineering, Faculty of Technology, Faculty of Medicine, Ramanathan Academy of Fine Arts (RAFA) and the Siddha Medicine Unit.

The Agriculture library is located in a newly built structure sharing the facilities with Computer unit. It serves the needs of the undergraduates of the faculty by providing the reference materials and services for learning. The library contains fairly good collection of wide spectrum of books and periodicals related to Agriculture. All the materials in the library are automated and made access through Web OPAC. The library provides large amount of subscribed databases and provide a range of services. Students have to register at the library before using the facilities. Books taken from stacks section (first year students - two books, second year students – 3 books and third and fourth year students – 4 books) can be kept for two weeks. Students can also take two books from reference section and should return next day before 8 am (overnight reference). Student should not make any damage to any books. In case, a book is lost or damaged, there will be a fine.

Opening hours:

- Weekdays - 8.00 am to 4.00 pm
- The Agriculture library is closed on Saturday, Sunday and Public Holidays.

5.2. The Computer Unit

The computer unit located at the Faculty of Agriculture premises serves as the provider of computer services for the Faculty of Agriculture. The computer unit was involved in conducting courses on information Communication Technology, Application in Bio-Statistics packages and other department specific software applications. At present, the Computer Unit has several labs each accommodates 50-60 computers. Out of which 3 laboratories are used

for conducting practical sessions, providing internet access for staff and students, conducting online examinations and taking student feedback. The Computer Unit also has one virtual learning class room, one audio visual laboratory and one interactive lecture hall. It also houses servers for running the network related services. Learning Management System (LMS) is available for enhancing teaching and learning process. Computer unit also provides extra mural services.

5.3. The Physical Education Unit

The Physical Education Unit of the University of Jaffna, situated behind the Medical Faculty, offers the following facilities for the students related to sports;

- The sports equipment and materials
- Facilitating and conducting inter-faculty and inter-university meets, freshers' meet and friendly matches and tournaments
- Conducting colours awarding ceremony.
- Affiliating with outside sports associations.

The Sports Complex has a large playground where Courts for Tennis, Basketball, Hockey, Cricket, Soccer, Netball, Volley ball & Elle have been set up and maintained. The Physical Education Unit provides about more than 26 games to the students: Athletic, Badminton, Basketball, Carrom, Chess, Cricket, Elle, Gymnastic, Hockey, Karate, Netball, Rugby, Soccer, Table tennis, Taekwondo, Volleyball, Weightlifting, etc. Facilities for different indoor games as well as outdoor games are also available the Faculty of Agriculture.

A sports complex has been established in the Kilinochchi premises with facilities available for the above. Coaches are visiting the Kilinochchi premises to provide coaching for Karate, Netball, Rugby, Soccer etc. according to a time table. In addition a large playground is located near to the Faculty of Agriculture.

5.4 Well-being (We-Be) Centre

A Centre for nurturing the well-being of students located in the main university. It, seeks to strengthen and develop every aspect of a person's life. It is an effort to make university life a fruitful and rewarding experience for all students by helping them achieve holistic personal development. Students shall seek trained counsellor, for many issues such as, interpersonal problems, Academic difficulties, alcohol and drug issue, physiological problem and adjustment issue.

The centre has a regional centre at Kilinochchi combining the three faculties and a Deputy Director is appointed. In addition, each faculty has a WeBe Cell under the assistance of a WeBe Coordinator. All these branches student representation is ensured to listen their voices. Further it is currently establishing Well-Being Faculty Clubs to facilitate the students in other activities. The centre has staff trained in counseling and psychosocial support activities. In addition, outreach services are being provided at Kilinochchi premises. A mentorship and befriending programme by trained senior students is available through this centre.

Well-being centre for:

Interpersonal problems

- Difficulty in our lives with a friend, teacher, students, administration or a member of the opposite sex.
- Discomfort, worries, distress and hurt.
- Poor self-esteem and confidence.

Academic difficulties

- Relieving Exam Tension
- Study skills training and report writing
- Memory enhancement techniques

Alcohol and drug use

- Withdrawal, control use and abstinence
- Dependence, Addictions

Adjustment issues:

- Transition from school to university life.
- Transition from home to hostel life.

Psychological problems

- Stress, Anxiety and Depression
- Somatization
- PTSD
- Suicidal ideation
- Sexual Difficulties
- Obsessions

5.5 Centre for Gender Equity & Equality (CGEE)

Centre for Gender Equity & Equality is located at the 2nd floor of the Health Centre, University of Jaffna. The intention of this Centre is to instituting socially and gender-sensitive University sub-culture and an environment of freedom and security that allows students to pursue their study without discrimination and oppression. This University of Jaffna promote equality between women and men and eliminate unlawful discrimination and harassment and provide an inclusive working, learning and social environment in which the rights and dignity of all students are respected to assist them in reaching their full potential. The GEE Centre shall consist of the members from council, academic staff, nonacademic staff and 6 elected representatives from students. Among them 3 males and 3 females. Further details could be obtained from <https://www.unit.jfn.ac.lk/cgee/>.

GEEC of the University of Jaffna included with several sub-committee: Resource Mobilization working Committee; Education and Research working Committee; Grievances Committee;

Monitoring working Committee. Students can lodge complaints and seek support related to sexual and Gender Based Violence (SGBV).

5.6 Career Guidance Unit (CGU) and Career Guidance Cell (CGC)

Career guidance unit of the university of Jaffna functions with the main objectives as to help and guide the undergraduates in their efforts to undertake career education, career exploration, career choice, career planning and career management. Career guidance advisory board is the governing body consisting Vice Chancellor, Deans of the faculties, Director/CGU, academic career guidance advisor and Chairman/student counselors. Career guidance cells function in faculty level by the chairman consisting 3 members. They initiate the career guidance activities in their faculty and liaison with career guidance unit.

5.7 University Business Linkage (UBL) Cell

The University Business Linkage (UBL) Cell at university level and at each faculty level were established recently with the vision to achieve sustainable growth for MSMEs in the regional economy through tacit collaboration between the university and public/private enterprises. The objective of the faculty level UBL cell includes establishment of joint research, student mobilization in assisting issues confronted with agro based MSMEs of the dry zone, initiating the formation of faculty enterprise unit and students' enterprise club to increase the linkages between students and agro based enterprises and encouraging final year graduates on practically oriented thesis and adaptation.

5.8 Academic Counseling and Mentoring Mentoring

Academic advisors (Mentors) are appointed for each student by the Faculty Board of the Faculty of Agriculture. Academic advisors

provide guidance to the students related to their academic activities. The main purpose of mentoring is to maintain good academic relationships with students and support them to manage the difficult time. The mentoring shall facilitate the students to build their self-confidence and help them in career planning. The mentoring process begins with the introduction of mentors to students and continues until the student graduates. Students are encouraged to meet with their mentors on a regular basis to get academic guidance. The time table of the semester allows the students to meet their academic advisors once in a week. The students should fill the record books provided by the academic advisor in weekly basis.

Student Counseling

Student counselors are appointed by the Vice-Chancellor of the University and they are responsible for providing support and serving as liaison between Dean/Agriculture, lecturers and parents, utilizing conflict resolution strategies, peer relationship support, behavioral and organizational management support and coordinating the support programs for students.

5.9 Response Management System at University of Jaffna Faculty Response Management Committee

A Faculty Response Management Committee shall be established at each Faculty. The said committee shall be authorized to receive written concerns pertaining to the commission and omission of academic and administrative activities within the faculty, which need prompt official responses with respect to effective settlement/action in progress. All categories of staff members and students of a Faculty in the University who have exhausted the available mechanisms within the Faculty, shall report to the Response Management Committee of the respective Faculty of their concerns of different nature (inter alia complaints, grievances, proposals, suggestions) except the ones excluded from the scope of the committee, in writing, and those who

have approached the committee shall possess the right to obtain appropriate responses within a month from the date of the communication.

The Faculty Response Management Committee shall consist of

- Two senior academic staff members, two student counsellors, and an academic counsellor appointed by the Dean of the Faculty on receipt of the expression of interest.
- DR/SAR/AR of the Faculty shall serve as the Secretary to the Committee

The Committee shall discharge the following functions:

- (a) Receiving concerns of various nature including complaints, grievances, suggestions, and proposals, in writing, from all staff members and students attached to the Faculty.
- (b) Studying the concerns submitted to the attention of the Committee
- (c) Conduct all relevant activities required for the effective management of the reported concern including hearing, inquiries, collection of evidence, calling of explanations
- (d) Providing appropriate responses in writing within one month from the date of receipt of the concerns through the Dean of the Faculty
- (e) Obtaining expert opinion, if necessary, to respond to the concern

University Committee on Response Management

The University Committee on Response Management shall be authorized to receive appeals from any stakeholder of the University who is dissatisfied with the responses given or not given a response within one month by the Faculty Response Management Committee. Those who have approached the University Committee on Response Management shall possess the right to obtain appropriate responses within two weeks from the date of submission of appeals.

The University Committee on Response Management shall consist of

- (a) Three Professors appointed by the Vice Chancellor
- (b) The registrar or his/her nominee shall serve as the Secretary to the Committee
- (c) Grievance and redressal committee at the University level is existing for placing the grievances which are not dealt by response management committee.

5.10. Active Citizenship

Active Citizens connects people, supporting them to develop their skills and knowledge to build fairer and more resilient societies. The most important thing that Active Citizens have in common is that they seek to build trust within and between communities. And they do this with resourcefulness and imagination. Active Citizens is a non-profit program that promotes community cohesion and improvement through civic engagement or volunteering in around 30 countries. The Active Citizens program envisages a world in which these increasing global connections lead to positive outcomes, where youth feel empowered to actively engage in the development of their communities. We think this vision is important at a time when decisions taken locally can have an immediate impact globally and vice versa. By joining this program, participants will be able to:

Develop a strong sense of their own culture and identity through engagement with other cultures

- Have an increased knowledge and understanding of how their local community works and its links to the rest of the world
- Take action to improve society through sustainable initiatives
- Work effectively with diverse groups of people

- Become skilled in cross cultural communication and dialogue, and its effective role in community action

The program works with young people who have demonstrated they have taken local social responsibility; including youth workers, women's groups, educators, community development professionals, voluntary sector representatives and religious leaders. Working together, they build trust and understanding, develop skills and deliver Social Action Projects (SAPs). These projects are focused on important issues their communities face - such as poverty, gender discrimination, violation of human rights and environmental pollution. Young leaders then engage with their local communities through SAPs. Partner organizations, local government and community influencers can support these young leaders through mentoring, providing access to resources and technical support.

6. Other Services

6.1 Health Center

A health center is located at the Faculty of Agriculture to provide medical facilities to the students. A medical doctor (General Hospital, Kilinochchi) and Pharmacist (General Hospital, Kilinochchi) visits from 4.30 pm to 6.30 pm on working days and a nursing officer visits from 10.00 am to 6.30 pm on working days. Agriculture students who wants to get a medical or certified medical can meet doctor on every Tuesday (The have to submit the medical submission form and relevant documents to medical officer).

6.2 Canteen and Shop

The Faculty of Agriculture has two canteens to cater the needs of the students at reasonable prices. Main food and beverages are supplied by the main canteen, while natural fruit juices and short-eats are supplied by the other canteen. A shop out let is also available within the premises to cater the day to day needs of students.

6.3 Banking Facilities

ATMs of Bank of Ceylon and Peoples Bank are located near to the entrance of the Faculty.

6. 3. Financial Aids

Financial assistance available to students studying BSc Hons (Agriculture) at the University of Jaffna are as follows:

6.3.1. Mahapola Trust Fund

Mahapola scholarships are awarded to students entering the Universities of Sri Lanka based on their performance at the G.C.E. (A/L) Examination. Selection to this scholarship is made by the University Grants Commission. Two categories of Mahapola scholarships are awarded. Payments are made in 10 installments per academic year and a student receives a sum of Rs.5050 per month under the merit category or Rs.5000 per month as ordinary category. An undergraduate following the BSc Hons (Agriculture) course will normally receive a total of 40 installments (10 installments for the four-year duration course. Monthly installment of Mahapola Scholarship is directly credited to the bank account of the scholarship recipients. Selected students should mandate a bank account at any Bank and to submit the details of account to the Welfare Branch for payment arrangements. These scholarships can be suspended or cancelled when a student's work, conduct or attendance is unsatisfactory.

6.3.2. Bursary Scheme

Bursaries are awarded to eligible students who do not receive Mahapola scholarship. Needy students should make an application to the Student Welfare Branch of the University. The selections for the bursaries are made on the basis of parental income/the number of siblings under 18 years and the distance from home to the University. Monthly installment of bursary payment is Rs. 4000 for merit category and Rs. 3,900 for ordinary category.

6.3.3 Endowed Scholarships

Selection of students to Endowed scholarships is operated by the University Grants Commission (UGC). Students can apply for Endowed Scholarships when applications are called for such scholarships either by the UGC or respective universities.

6.3.4 Vice-Chancellor Welfare Fund

This fund is available to help the poor students who need financial assistance. Students can apply for the Vice-Chancellor welfare fund on the prescribed form issued by the Welfare branch.

7. Gold medals and Prizes

The following gold medals and prizes are available for the students for their performance in academic and extracurricular activities.

7.1. Professor Alagaiah Thuraiajah Gold Medal - University Level

For all round performance in both academic and extracurricular activities in the University of Jaffna.

7.2 Prof. K. Kunaratnam Gold Medal

For best all round performance in both academic and extracurricular activities among pure and applied science students.

7.3. Professor Alagaiah Thuraiajah Gold Medal - Faculty Level

For all round performance in both academic and extracurricular activities at faculty level

7.4. Late Mrs. Puvaneswary Loganathan Memorial Gold Medal

This memorial gold medal is awarded to a student who obtains the highest OGPA in the award of Degree of Bachelor of Science Honours in Agriculture with a minimum of second class upper division.

7.5. Late Mrs. Puvaneswary Loganathan Memorial Gold Medal for Agronomy

This memorial gold medal is awarded to a student who specialized in Agronomy and obtains the highest OGPA in the award of Degree of Bachelor of Science Honours in Agriculture with a minimum of second class upper division.

7.6. Late Mr. Senior Nadarajah Gold Medal for Animal Science

This gold medal is awarded to a student who specialized in Animal Science and obtains the highest OGPA in the award of Degree of Bachelor of Science Honours in Agriculture with minimum a of second class upper division.

7.7. Late Dr & Mrs C. Jeyaratnam Memorial Gold Medal for Agricultural Biology

This gold medal is awarded to a student who specialized in Agricultural Biology and obtains the highest OGPA in the award of degree of Bachelor of Science Honours in Agriculture with a minimum of second class upper division

7.8. Late Dr & Mrs C. Jeyaratnam Memorial Gold Medal for Agricultural Chemistry

This gold medal is awarded to a student who specialized in Agricultural Chemistry and obtains the highest OGPA in the award of degree of Bachelor of Science Honours in Agriculture with a minimum of second class upper division.

7.9. Eng. R. Vijayaratnam Memorial Gold Medal for Agricultural Engineering

This gold medal is awarded to a student who specialized in Agricultural Engineering and obtains the highest OGPA in the award of degree of Bachelor of Science Honours in Agriculture with a minimum of second class upper division.

7.10. Prof. Somasundaram Kandiah Endowment Prize

This endowment prize is awarded to a student for the best overall performance in core-course units of Agronomy in the award of Degree of Bachelor of Science Honours in Agriculture with a minimum of second class upper division.

7.11. Ratnam Reginold Dharmaratnam Memorial Prize

This award is awarded to a student for obtaining highest OGPA in the Award of Degree of Bachelor of Science Honours in Agriculture with a minimum of second class upper division.

7.12. J. M. Rajaratnam Scholarship

To be awarded to the best Vadamardachy student entering the Faculty of Agriculture (based on the G.C.E. (A/L) examination results. If there is no student from Vadamardachy, it may be offered to the best student whose wage earning parent had died or got totally incapacitated as a result of the ethnic conflict.

7.13. Thillainayagi Kanagasabapathy Scholarship

Awarded for the best overall performance at the end of second examination in Agriculture.

7.14. Sellachi Shanmugam memorial Scholarship

Awarded for the best overall performance at the end of third examination in Agriculture.

7.15. University Prizes (Thambiah Mudaliyar Chatram Trust)

The above prizes are given for the best performance in the First year, Second year, Third year and Fourth year and best overall performance at the end of fourth year.

7.16. Canberra Tamil Association (CTA) Scholarship

This Scholarship is awarded for the best research project submitted in the Fourth Examination in Agriculture.

7.17. Dean Merit Certificate

The above prize is awarded for the students who perform well in the final year research project from each specialization subject.

7.18. Faculty Awards

Faculty award shall be awarded to the overall best-performing students of each academic program in the faculty, at the end of each academic year. Annually the best five outstanding students from each academic program from each batch shall be selected based on the guidelines. Awards shall be administrated by the office of the dean of the faculty with the assistance of examination and student affairs branches. The applicant should have a GPA of 3.30 or above. Apart from academic merit, other areas of consideration are exceptional leadership, community service and good studentship, outstanding talents in fields of sports, creativity, and exceptional ability in aesthetic or technical fields and research or pursuing new knowledge.

7.19. Dean's List

A student of any program in the faculty could be admitted to the dean's list each semester if the student achieves a GPA equal to or more than 3.70. This award shall be administrated by the office of the dean of the faculty with the assistance of examination and student affairs branches.

8. Awards of Full / Half Colours

Students who perform well in sports are eligible to get colours or half colours based on their performance in sports. Criteria for the award of colours/half colours for the sportsmen and sportswomen of the university of Jaffna is available in the Constitution of the University of Jaffna Sports Council (<http://www.unit.jfn.ac.lk/peu/index.php/downloads/>). The requirements for the colours/ half colours should have been fulfilled through the Inter University Tournament matches or any other tournament matches recognized by the Director of Physical Education. Physical education unit and Sports Council of the University of Jaffna organize the Colours Nite at the end of every year to award the colours.

9. Students' Union

Agriculture Students' Union, has been established to represent all the students of faculty, constituting the following members:

- The Patron - Dean of the faculty
- Senior treasurer (permanent member of the academic staff)
- President
- Vice-President
- Secretary
- Asst. Secretary
- Editor
- Junior Treasurer
- Committee members - Two members
- Student representative - Two members (Gender balance)

Committee shall be elected within one month of the beginning of third year second semester and shall hold office normally for one year until the election and assumption of office by the next Executive Committee. All eligible members shall have the right to elect or to be elected to the Executive Committee, provided that no first year shall have the right to contest for the posts of President, Secretary and Junior Treasurer. The duties and functions of a Faculty Students Union shall be:

- Promote the corporate life and welfare of the student community of the Faculty
- Take steps to encourage and further the academic interests of its students
- Safeguard and protect the good name of the Faculty and Institution
- Foster cultural and sports activities amongst the students of the Faculty
- Make recommendations to the University Students Union on matters pertaining to the disbursement of the funds and the General welfare of the student community of the Faculty
- Ensure that all decisions of a Faculty Students Union pertaining to the academic and welfare activities of the Faculty

The elected student's union shall function for one-year period as mention in table 18

Union shall carry out following activities with prior permission from respective staffs.

Table 18: Activities and time frame of Student Union

Activities	Time frame
Commencement of Student union	The activity of student union commence on third year second semester
Supporting to the Orientation	Student union shall support the orientation programme with the arrival of new batch
Agros' week and Agros' night	1 week period is allowed to conduct Agros' week and Agros' night. The period will be included in the calendar of dates (with in first half of fourth year first semester)
Coordinate religious and cultural activities in faculty level	Student union shall coordinate any time of their active period
Blood donation campaign	Student union shall conduct any time of their active period
Release of Pasunthokai article	Student union shall conduct any time of their active period
Hand over the activities to new union from existing union	The activities of Student union shall be handover to new union at the end of fourth year first semester.
Balancing the account	The old student union shall balance the account with in 1 week period after handover

Note:

In addition to above activities, the student Union shall carry out other activities related to enrich academic and welfare of the faculty with prior permission from respective staffs.

10. Fees

Fee payable by the students is determined by the decisions made by the university authorities.

Description		Rate (Rs.)
Registration		250
Student Charter		100
Student Identity Card		250
Medical Fee		250
Lab Deposit		500
Hand Book		250
Orientation Fee		250
Library Deposit		500
Renewal of Registration		150
Record Book		Free Of Charge
Duplicate record book if lost		1000
Duplicate record book if damaged		500
Duplicate Identify card if lost		1000
Duplicate Identify card if damaged		500
Examination Entry Fee		No Fee For Proper Candidate
As repeat candidate		250
Submission on MC		250
Upgrading results		250
Duplicate Exam Admission card		150
Convo cation	Degree Certificate	500
	Cloak Fee	500
	Supplication Fee	500

	Cloak if lost / damaged	500
	Cloak if delay payment	500 per day
	Garland if lost / damaged	1000
Statement of results Fee		100
Duplicate results sheet		500
Transcript		100+postage
Transcript – Online Procession		500
Issue of copy of Curriculum		100
Transfer Certificate		100
Bursary Book		Free Of Charge
Duplicate Bursary Book if lost		1000
Duplicate Bursary Book if damaged		500
Hostel Fee		200 per month
Hostel deposit / Admission Fee		250

11. Ethics

Unethical and Unlawful Activities that are prohibited in Universities

Plagiarism and Cheating: Undergraduates are required to maintain high academic standards and commit themselves to academic honesty in their academic work and examinations. Copying, plagiarism or keeping unauthorized material at examinations, copying or reproducing work of others in students' reports or theses or assignments without disclosing the source of information are not allowed.

Disorderly Conduct, Dissent and Protests: Students' conduct violating the contemporary community standards of morality and/or in violation of university norms will not be tolerated. Any type of offensive or vulgar or rude or indecent conduct in campus or at university sponsored events, on or off campus will also not be tolerated. Organizing, sponsoring, implementing or conducting

programmes or activities which are disorderly and/or violation of civil laws or university regulations are prohibited and will be subjected to disciplinary action.

Disrespect and Non-compliance: Failure to comply with the directives of university officials acting in performance of their duties is prohibited. Disciplinary action can be applied in such situations including, but not limited to, the following acts:

- Use of abusive or insulting language
- Engaging in indecent and unbecoming gestures
- Providing fraudulent or false information to university officials
- Showing disrespect or refusing to comply with a reasonable request from a university official
- Not responding to a reasonable request within a specific timeline, including absence for assigned appointments
- Intentionally and knowingly interfering with teaching
- Obstructing or hindering the investigation of an incident

Wrongful Utilization of Goods, Services or Information: Students are required to demonstrate sincerity and honesty in their dealings with the university and the public.

Unauthorized Collection of funds: Any solicitation of funds for a university purpose, whether organized by students or by the authority, should be pursued only with proper authorization of the ViceChancellor. Any external communications requesting sponsorships or funds should be done by a letter addressed to the external organization under Vice Chancellor's approval and signature. Without such approval, solicitation for or collection of funds for political purposes or purported charitable or social activities is not allowed either within or outside the premises.

Solicitation: No outside person, organization or business may solicit on the university campus without the express permission of the Vice Chancellor. This includes holding meetings, distribution of any type of leaflet, or posting, exchange of goods or services and bartering or selling of services or goods.

Possession and consumption of alcohol, drugs and tobacco within the university premises: The state universities adopt a code of practices that prohibits possession and consumption of alcohol, drugs and tobacco within the university premises. Hence, students are strongly advised to refrain from bringing alcohol into the campus and to any premises of the university. Students are discouraged from entering the university premises after consuming alcohol and/or drugs.

Gambling: Gambling is not permissible within the campus. Any form of betting, acceptance of bets, payment or running of any betting scheme is not permitted. Any student/s caught gambling will be punished under the prevailing law and university regulations.

Harassment/Violence: Harassment of an individual or group of individuals or inciting violence inside or outside the university is a punishable offence under the civil law and the civil law regarding harassment and violence is equally applicable both inside and outside the university.

Hazing/Ragging: Universities are havens for the independent pursuit of academic excellence. Ragging or hazing has reduced and diminished the freedom or independence of students and it hinders the achievement of academic excellence.

Hazing or ragging is interpreted as any act (by an individual or group) whether physical, mental, emotional or psychological, which subjects another person, voluntarily or involuntarily, to anything that may abuse, mistreat, degrade, humiliate, harass or intimidate whether on or

off the campus. These actions are prohibited and include, but are not limited to, the following.

- Forcing individuals to perform and/or engage in demeaning or humiliating acts
- Bullying or coercing, or intimidating individuals or group of individuals.
- Creation of excessive physical or mental fatigue
- Causing physical or psychological shocks
- Forcing to wear clothing which is conspicuous or bad in taste
- Forcing an individual or individuals to engage in morally degrading or humiliating acts, games or activities
- Forcing individuals or group of individuals to engage in early morning or late evening work sessions which are not in conformity with norms of civil society and/or that may interfere with academic performance

Body marking/painting or any activity that is not consistent with the policy of the university which would adversely affect the University's mission and damage its image.

Sexual Harassment/Sexual Misconduct: The university students population is a mixed, usually in equal proportions of males and females. The freedom to engage in sexual behavior cannot be practically restricted other than on moral and ethical grounds. If any person under the university administration commits an act of sexual harassment or misconduct by trying to impose their sexual desires on another person, be it a person of the opposite sex or of the same sex, and if a complaint is received, action will be taken under the prevailing law to bring justice and punish the offender.

Theft: Stealing physical goods as well as stealing intangible assets such as intellectual properties (plagiarism; i.e. academic and research

work and innovations of others) are punishable offences under the civil law as well as under the university disciplinary procedures.

Vandalism: Vandalizing property in the university or provoking others to do so will be dealt with under the law of the land concerning public property and privately held assets, and the university regulations. Damage due to vandalism to class room furniture, hostel furniture, laboratory equipment, computers and accessories, and playground equipment will be charged to the students, if they are found guilty

Unauthorized Entry: Universities impose restrictions regarding persons entitled to use its assets. Normally all students are given unrestricted access during working hours to the class rooms, libraries, play grounds, gymnasium areas etc. Students have access to their hostels but no visitors are permitted without approval of the warden of the hostel.

Co-operation with Authorities and Committees of Inquiry: Universities appoint various committees of inquiry on disciplinary matters and empowered officers may summon students to provide verbal or written evidence. On such events it is necessary for students to cooperate with the authorities.

Right of Appeal: Right of appeal is enshrined in the fundamental rights up until the level of the Supreme Court. This principle applies to the university as well, and therefore one can appeal to the Vice Chancellor against a decision given by the disciplinary authorities regarding any matter. This may be done collectively or individually and a fair hearing for such appeals will be given by the Vice Chancellor through appropriate channels.

12. Officials of the University

Head of the University

The Chancellor

Emeritus Prof. S. Pathmanathan

Officers

The Vice Chancellor

Prof. S. Srisatkunarajah

Dean/Agriculture

Prof. S. Vasantharuba

Dean/Allied Health Sciences

Mrs. D. Thabotharan

Dean/Arts

Prof. S. Raguram

Dean/Engineering

Dr. K. Pirapaharan

Dean/Graduate Studies

Prof. S. Kannathasan

Dean/Hindu Studies

Mr. Sarveswara Iyer Padmanaban

Dean/Managements Studies & Commerce

Prof. N. Kengatharan

Dean/Medicine

Prof. R. Surenthirakumaran

Dean/Science

Snr. Prof. P. Ravirajan

Dean / Technology

Prof. (Mrs.) S. Sivachandiran

Dean/Sir Ponnambalam Ramanathan Faculty of Performing and Visual Arts

Mr. S. Sivaruban

Registrar

Mr. V. Kandeepan

Librarian (Acting)

Dr. S. Ketheeswaren

Bursar

Mr. K. Sureshkumar

12.1 Principal Officers of the Faculty of Agriculture, University of Jaffna

Dean:

Prof. S. Vasantharuba

Heads of Departments:

Dept. of Agronomy	Dr. (Mrs). L. Pradheeban
Dept. of Animal Science	Prof (Miss) J. Sinniah
Dept. of Agric. Biology	Prof. K. Pakeerathan
Dept. of Agric. Chemistry	Prof (Mrs.) N. Gnanavelrajah
Dept. of Agric. Economics	Dr. K. Sooriyakumar
Dept. of Agric. Engineering	Dr. N. Kannan

Senior Assistant Registrar:

Mr. A.P. Vijayaratnam

13. Academic Staff of the Faculty of Agriculture

Department of Agronomy

Prof. (Mrs.) S. Sivachandiran	Professor
Dr. (Mrs.) L. Pradheeban	Senior Lecturer (Gr. I)
Mrs. K. Nishanthan	Senior Lecturer (Gr. I)
Mr. K. Jeyavanan	Senior Lecturer (Gr. II)
Dr. (Mrs.) S. Selvaskanthan	Senior Lecturer (Gr. II)
Dr. R. Eeswaran	Senior Lecturer (Gr. II)
Mr.G.Asharp	Lecturer (Prob.)

Department of Animal Science

Prof. (Miss.) J. Sinniah	Professor
Dr. (Mrs). S. Piratheepan	Senior Lecturer (Gr. II)
Mr. S. Thadsaneshkanth	Lecturer (Confirmed)
Mr. S. Anand Kumar	Lecturer (Prob.)
Mrs. S. Thiruchchenthuran	Lecturer (Prob.)

Department of Agricultural Biology

Prof. G. Mikunthan	Senior Professor
Prof. G. Thirukkumaran	Professor
Prof. K. Pakeerathan	Professor
Dr. S. J. Arasakesary	Senior Lecturer (Gr I)
Dr. T. Suvanthini	Senior Lecturer (Gr II)
Mr. N. Thiruchchelvan	Lecturer (Prob.)
Mrs. N. Thanushan	Lecturer (Prob.)

Department of Agricultural Chemistry

Prof. (Mrs.) N. Gnanavelrajah	Professor
Prof. S. Vasantharuba	Professor
Mrs. S. Sivakanthan	Senior Lecturer (Gr II)
Mrs. A. Kirisan	Lecturer (confirmed)
Mrs. A. Shayanthan	Lecturer (confirmed)
Miss. R. Sarathadevi	Lecturer (Prob.)
Mrs. K. Kajeewan	Lecturer (Prob.)

Department of Agricultural Economics

Dr. K. Sooriyakumar	Senior Lecturer (Gr. I)
Mr. K. Umashankar	Senior Lecturer (Gr. I)
Mrs. A. Sireerangan	Senior Lecturer (Gr. II)
Mr. S. Sarujan	Lecturer (Confirmed)
Mr. S. Sivashankar	Lecturer (Prob.)
Miss. R. Kamshajini	Lecturer (Prob.)

Department of Agricultural Engineering

Prof. (Mrs.) T. Mikunthan	Professor
Mr. M. Prabhakaran	Senior Lecturer (Gr. I)
Dr. N. Kannan	Senior Lecturer (Gr. II)
Mrs. A. Thushyanthy	Lecturer (Prob.)
Mrs. T. Thusyanthi	Lecturer (Prob.)
Mrs.T.Asharp	Lecturer (Prob.)

Computer Unit

Mr.A.Uthayakumar	Instructor in Computer Technology
Mr.K.Venugoban	Instructor in Computer Technology

Farm Unit

Mr. S. Sritharan

Farm Manager

Mr. G. Guberan

Assistant Farm Manager

Coordinators/Chairperson of the Cells/Sub committees of the Faculty

- Faculty Research Committee
Chairperson - Dr. (Mrs). L. Pradheeban
- Curriculum Development, Revision and Monitoring Committee
Chairperson - Dr. K. Sooriyakumar
- JICA Monitoring Committee
Chairperson - Prof. S. Vasantharuba
- Student Welfare Service Committee
Chairperson - Prof. (Miss.) J. Sinniah
- Gender Equity and Equality Cell
Chairperson - Dr. (Mrs). L. Pradheeban
- Faculty Outreach Activities Committee
Coordinator - Prof. K. Pakeerathan
- Academic Mentoring Committee
Coordinator - Dr. R. Eeswaran
- Internal Quality Assurance Cell
Coordinator - Dr. R. Eeswaran
- Well-Being Cell
Coordinator - Prof. K. Pakeerathan
- University Business Linkage cell
Coordinator - Dr. N. Kannan
- Sports Coordinators
Dr. N. Kannan and Mrs. K. Kajeevan
- MIS Agriculture and Web Committee
Coordinator - Mr. K. Venugoban
- Carrier Guidance Cell
Coordinator - Dr. S. J. Arasakesary

Wardens and Sub wardens

Female Hostel

Warden - Dr. (Mrs.) Hiranya Nawarathna (0775017556)

Sub Warden - Mrs. P. Mukunthakumar (0769305558)

Mrs. V. Paskaralingam (0770446168)

Male Hostel

Warden - Dr. S. Gowthaman (0772911120)

Sub Wardens - Mr. S. Srishankar (0761277552)

Mr. K. Kapilan (0763834641)

14. Telephone Directory

Administrative Office/Branch	Telephone Number
University - General Information	021 221 8101
University Security	021 221 8133
Vice Chancellor	021 221 8103
Registrar	021 221 8105
Bursar	021 221 8108
Assistant Registrar- Academic	021 221 8124
Computer Unit	021 222 2673
Librarian	021 222 2970
University Medical Officer (UMO) (Main University)	021 221 8130
Assistant Registrar / Welfare Services	021 221 8122
Deputy Registrar /Examination	021 221 8118
Senior Assistant Registrar /Administration	021 221 8112
Senior Assistant Registrar /Admission	021 221 8120
Director- Physical Education Unit	021 221 8131
Centre for Gender Equity and Equality	021 222 3748
Well-Being Centre	021 221 4067

Faculty of Agriculture/Kilinochchi Premises

Officer	Telephone Number
Dean/Agriculture	021 206 0175
Head/Dept. of Agronomy	021 206 0170
Head/Dept. of Animal Science	021 206 0176
Head/Dept. of Agric. Biology	021 206 0171
Head/Dept. of Agric. Chemistry	021 206 0172
Head/Dept. of Agric. Economics	021 206 0173
Head/Dept. of Agric. Engineering	021 206 0174
Computer Unit	021 206 0182
Deputy Registrar/Kilinochchi Premises	021 206 0180
Male Hostel	021 206 0177
Female Hostel	021 206 0181
Security office	021 206 0178

Student Support Officers

Officer	Telephone Number
Proctor Dr. A. Vengadaramana	0777110998
Deputy Proctor (Faculty of Agriculture) Prof. K. Pakeerathan	0776969511
Marshal (Main University) Mr. N. Vijenthira Mr. P. Gajanthan	0212229668 0773586590 0779226780
Marshal (Kilinochchi Premises) Mr. T. Indrakumar	0779050267
Director Students Welfare Prof. G. Sashikesh	0212229668 0776681425
Student Counsellors (Faculty of Agriculture) Dr. R. Eeswaran Mrs. Kasthuri Kajeewan Mrs. Thusalini Asharp	0771846700 0774233897 0779653379